

High Flow Safety Valves



 Engineering
GREAT Solutions

**Process and steam safety valves
to PED and DIN/EN standards**

Valve summary

Si 6301

Size
DN 20 to DN 150

Material
0.6025 / GG25

Set Pressure
up to 16 bar

Applications
Heating systems, drinking water,
low pressure steam generator



Si 4302

Size
DN 20 to DN 200

Material
1.0619 and 1.4408

Set Pressure
up to 40 bar

Applications
Vapours, gases and liquids in all industrial
applications



Si 6303-05

Size
DN 25 to DN 400

Material
1.0619, 1.4408 and 1.7357

Set Pressure
up to 250 bar

Applications
Protection of system components at high
pressure or large mass flow, for power
plants and industrial steam generators



Si 6106

Size
DN 80 to DN 300

Material
1.0619, 1.7357 and 1.7379

Set Pressure
up to 200 bar

Applications
Boiler and superheater in power plants and
industrial steam generators



Options

Contents

04 Useful knowledge

06 Si 6301

06	Features, applications, approvals and standards	Si 6301
07	Type code	Si 6301
08	Coefficients of discharge	Si 6301
10	Material code	Si 6301
11	Sizes, pressure ranges and dimensions	Si 6301

12 Si 4302

12	Features, applications, approvals and standards	Si 4302
13	Type code	Si 4302
14	Coefficients of discharge	Si 4302
16	Material code	Si 4302
18	Sizes, pressure ranges and dimensions	Si 4302

20 Si 6303 / Si 6304 / Si 6305

20	Features, applications, approvals and standards	Si 6303 / Si 6304 / Si 6305
21	Type code	Si 6303 / Si 6304 / Si 6305
22	Coefficients of discharge	Si 6303 / Si 6304 / Si 6305
24	Material code	Si 6303
26	Sizes, pressure ranges and dimensions	Si 6303
28	Material code	Si 6304
30	Sizes, pressure ranges and dimensions	Si 6304
32	Material code	Si 6305
34	Sizes, pressure ranges and dimensions	Si 6305

36 Si 6106

36	Features, applications, approvals and standards	Si 6106
37	Type code	Si 6106
38	Coefficients of discharge	Si 6106
39	Weld end (option .22)	Si 6106
40	Material code	Si 6106
42	Sizes, pressure ranges and dimensions	Si 6106

44 Trim code

45	Controlled safety pressure relief system
46	Safety valve with heating jacket (Option .18)
47	Technical design options

Useful knowledge

Safety valves have the function of preventing inadmissible overpressure in pipe systems, pressure vessels and boilers, in order to avoid danger to people, plant and the environment. They are set to a higher pressure than the operating pressure of the system to be protected.

Safety valves ...

- ... open once the set pressure is reached.
- ... steady discharge the required mass flow.
- ... close after the pressure has dropped.

Safety valves for pressure systems with low mass flow or where the mass flow is of marginal importance, e.g. with thermal expansion, are grouped in the IMI Bopp & Reuther application category **“Regular Flow”**.

The application category **“Proportional Flow”** comprises safety valves with proportional functional characteristics for special operating conditions.

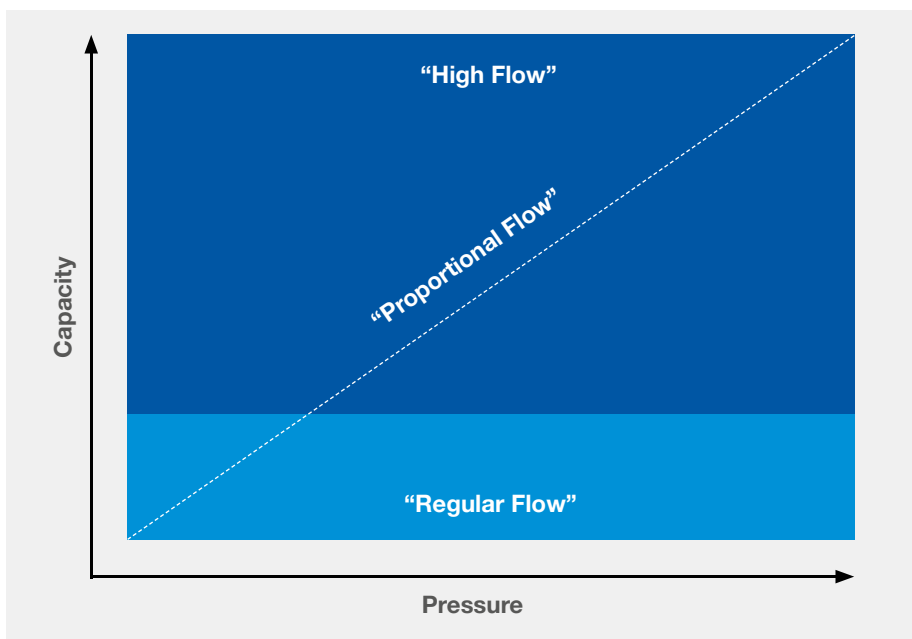

In the IMI Bopp & Reuther application category **“High Flow”**, the required capacity is usually the most important criteria for selecting a size. With reference to the inlet size, high flow valves can discharge the highest capacity and in particular on gas/vapour service open rapidly for instant pressure relief.

The size of the outlet is always larger than that of the inlet, in order to provide the fluid room for supercritical relief in the discharge. This way the back pressure building up in the body, which may affect the safe function, will not become excessively high.

Features and benefits

> Feature

Inlet sizes DN 20 to DN 400, up to 15 body seat sizes per pressure rating

Benefit

The variety of versions within the pressure ratings, temperature classes and sizes provides for a flexible choice helping to answer industrial requirements at low cost.

> Feature

One-trim design for vapours, gases and liquids. Only the spring selected for optimal function may be different.

Benefit

Easy to use the same valve when operating conditions change, as well as operational reliability in 2-phase flow. Reduction of spare part inventories and inexpensive maintenance.

> Feature

Maximum lift with lift stop for the certified capacity

Benefit

Stable position of the disc at full lift

> Feature

Bellows inside bonnet spacer outside the flow

Benefit

Bellows is protected from the flow impact, hence increased service life

> Feature

One-piece spindle, valve disassembly possible without set pressure change

Benefit

Easy maintenance and repair

> Feature

Supplementary special designs for the best possible safety valve configuration.

Benefit

Optimal adjustment of the safety valve to the operating conditions and function requirement

Conventional safety valve

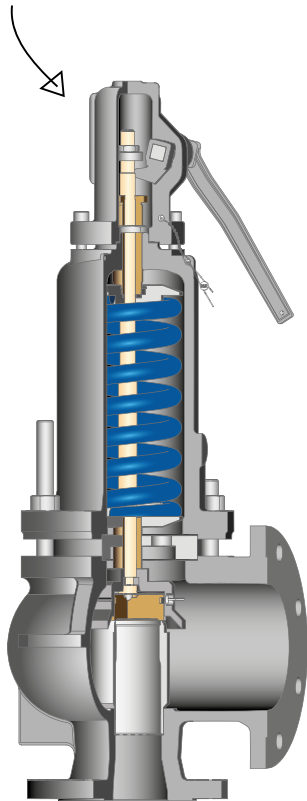

Safety valve with bellows

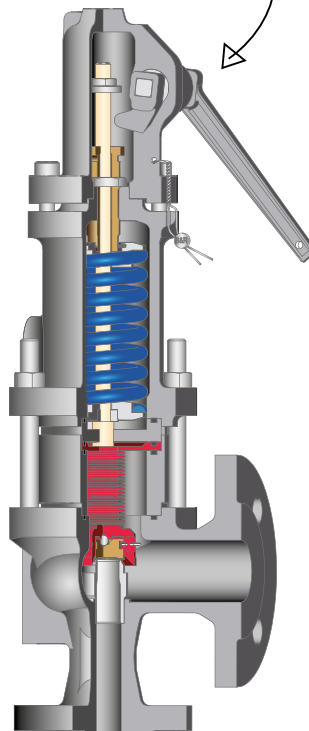

Safety valve with open bonnet

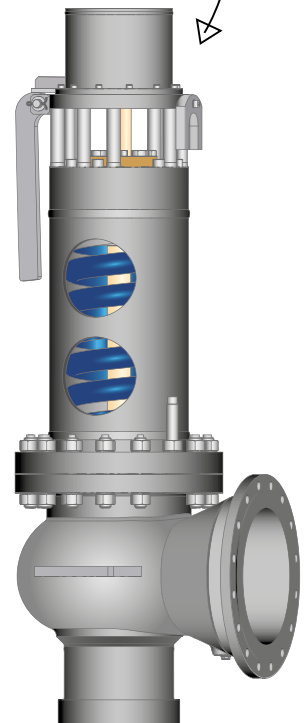

Conventional safety valve

The IMI Bopp & Reuther series Si 43 and Si 63 are most commonly used in process plants. The closed spring bonnet traps the process fluid in the valve and prevents a release to the environment. The straightforward construction and reliable guidance of the stainless steel inside parts ensure free and repeated discharge cycles. Conventional safety valves are usually selected where a short outlet pipe leads to the atmosphere, where the fluid is safely discharged into low pressure systems and where the fluid is non-critical.

The conventional safety valve limit for built-up back pressure is given for each type in this catalogue. In case of constant superimposed back pressure, a conventional safety valve is set to the differential pressure ($p - p_b$).

Safety valve with bellows

The Si 44 and Si 64 series are equipped with bellows between the body and bonnet. The following conditions require the selection of bellows:

- > Excessive built-up back pressure or variable superimposed back pressure. The bellows has a balancing effect on the back pressure.
- > When the fluid is highly viscous or contains solid particles that could enter the guiding areas. The bellows protects the guides.
- > When the fluid could have a corrosive effect on the inner parts. The bellows separates the bonnet chamber from the flow.
- > In case of media with a very high temperature. The bellows shields the spring against overheating.

Safety valve with open bonnet

In the safety valve series Si 41 and Si 61, the spring bonnet has an open design. The resulting ventilation of the bonnet chamber permits a standard steel spring to be used in fluid temperatures up to 400°C. The lifting lever makes this design particularly suitable for steam applications.

In higher temperatures, a bonnet spacer between the body and bonnet can provide the spring with further protection from overheating (design option .15), or a bellows can be additionally integrated as the best possible measure (type Si 45 and Si 65).

Si 6301

Features

Cost-efficient IMI Bopp & Reuther low pressure safety valve:

- > Semi nozzle design
- > Cast iron body with stainless steel inner parts (except for spring and spring washer)

Inlet sizes

DN 20 to DN 150

Inlet pressure rating

PN 10 to PN 16

Set pressures

0.45 bar g up to 16 bar g

Temperature range

-10 °C to + 300 °C

Overpressure

Vapours / gases	5%
Liquid	10%

Blow down

Vapours / gases	10%
Liquids	20%

Allowable built-up back pressure

15% of the set pressure

Basic valve for low pressure

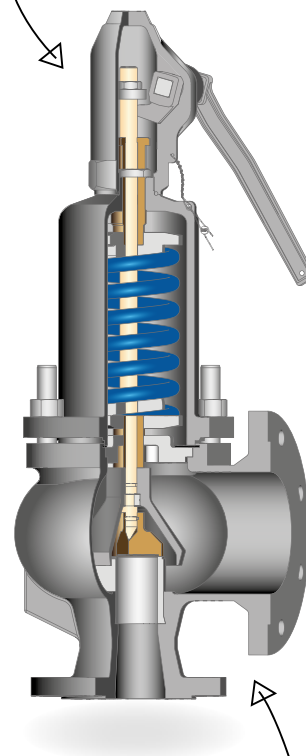

Economic for Heating system and water use

Applications

- > For vapours, gases and liquids
- > Hot water from heat generation plants in full acc. to TRD 721, EN 12828 with admissible supply temperatures up to 120 °C (acc. to TÜV certification 660)
- > Steam applications up to PN 16
- > Potable water

Approvals and standards

EC type examination

- Pressure Equipment Directive 97 / 23 / EC
- DIN EN ISO 4126-1
- AD 2000-Merkblatt A2
- VdTÜV Merkblatt "Sicherheitsventil 100"

VdTÜV type approval acc. to

TÜV.SV.12-1134.d₀.D / G / F.α_w.p
 TÜV.SV.12-660.d₀.D / G / H.α_w.p

IMI Bopp & Reuther will not renew the existing VdTÜV type approvals. The requirements by VdTÜV and applicable standards are completely considered by the EC type examination.

The design, manufacture, testing and labelling meet the requirements of DIN EN ISO 4126-7, DIN EN 12266-1 / -2 (insofar as applicable to safety valves), DIN EN 1092 parts I and II Flanges, AD 2000-Merkblatt A4, AD 2000-Merkblatt HP0, technical rules for steam boiler TRD 108, TRD 110, TRD 421

Si 6301

Type code

Type code				Order example
1	Series	Si 6	DIN/EN valve	Si 6
2	Design	3	Conventional, closed bonnet	3
3	Characteristic	0	High capacity "High Flow"	0
4	Pressure class	1	Up to PN 16	1
5	Cap	A	Packed lifting lever	A
6	Material code	05	EN-GJL-250/5.1301 GG25/0.6025/EN-JL 1040	05
7	Options	.11a	Disc with soft seal EPDM	
		.35	Lift restriction ring	
		.58	Diaphragm seal	

Type ▶	Si 6301 A 05	
Please state ▶	Set pressure	8.0 bar g
	Fluid temp.	80 °C
	Fluid and State	Water, Liquid
	Inlet	DN 50, PN 16, B1
	Outlet	DN 80, PN 10, B1
	Flow diameter	40 mm
	Approval	97/23/EG (CE)

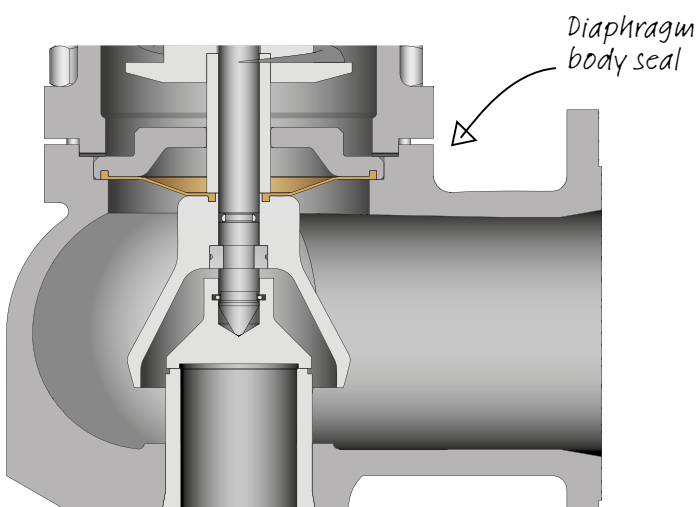

The special design with diaphragm seal (option .58) serves to tightly seal the spring chamber and guides, as well as protecting the sliding parts. The spring bonnet is equipped with a 10 mm diameter vent opening. Option .58 is usually selected for safety valves in heating technologies.

Si 6301

Coefficients of discharge

Fluid group	Inlet size	Flow diameter	$h/d_0 \geq$	$p_b/p_0 \leq$	α_w
Vapours / gases (D / G)	DN 20 to DN 100	16 mm to 77 mm	0.34	0.25	0.78
	DN 125 to DN 150	93 mm to 110 mm	0.36	0.25	0.78
Liquids (F)	DN 20 to DN 80	16 mm to 63 mm	0.34	-	0.6
	DN 100	77 mm	0.36	-	0.6
	DN 125 to DN 150	93 mm to 110 mm	0.36	-	0.52

The coefficient of discharge for gases / vapours in a pressure ratio of $p_b/p_0 > 0.25$ is shown in the diagram below.

The capacity of the selected safety valves can be adjusted to the required capacity by reducing the lift, thus reducing undesirable extra performance. The following applies:

$$\alpha_{w(\text{reduced})} = \alpha_w \times q_m / q_{mc}$$

The required ratio h/d_0 is shown in the diagram below, and the reduced lift calculated with $h_{(\text{reduced})} = d_0 \times (h/d_0)$.

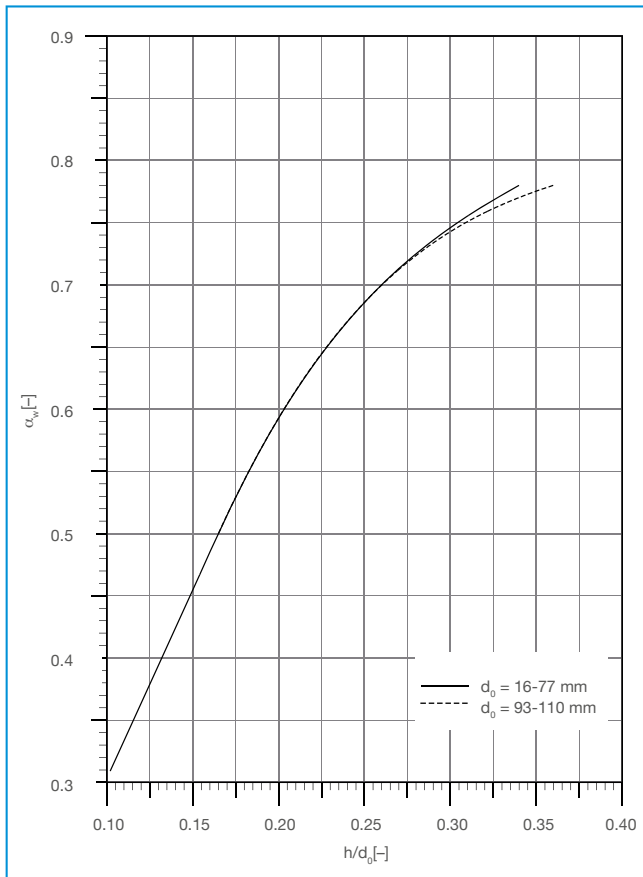

Si 6301 coefficient of discharge α_w depending on h/d_0 for gases and vapours

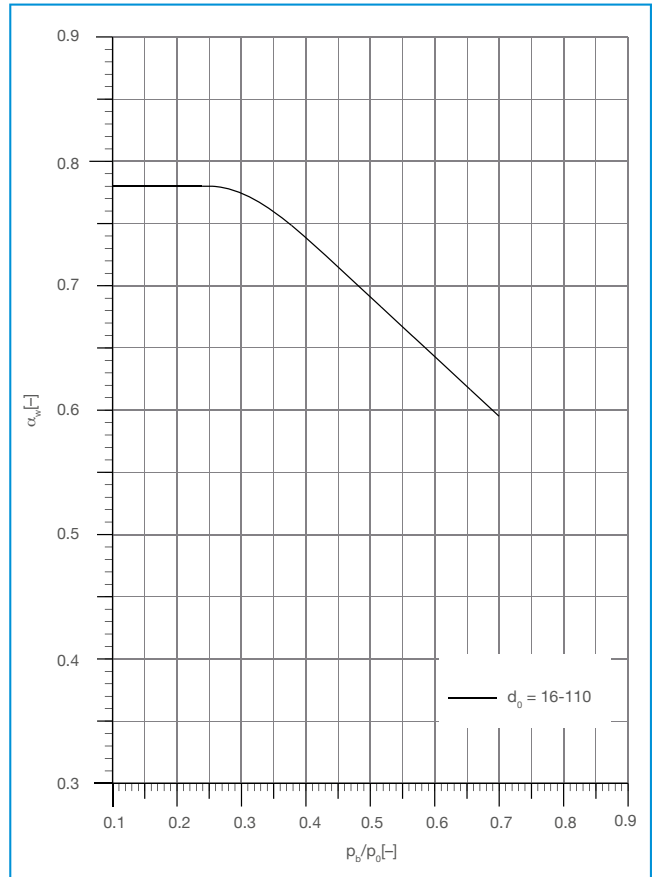

Si 6301 coefficient of discharge α_w depending on p_b/p_0 for gases and vapours

Si 6301

The coefficients of discharge K_{dr} acc. to DIN EN ISO 4126-1 for this valve series are identical with above coefficients of discharges α_w and the values in the diagrams.

Safety valves intended for discharging hot water from heat generation units or plants are approved in a separate EC type examination. The coefficients of discharge are given in the below table. The set pressure is limited to a 1 bar g to 10 bar g range.

Coefficient of discharge for hot water applications

Set Pressure [bar g]	Coefficient of discharge α_w
1.0	0.69
1.5	0.74
2.0	0.76
2.5 to 10	0.78

The corresponding interim values for the set pressure range from 1 bar to < 2.5 bar need to be interpolated. Applicable for $h/d_0 \geq 0.36$.

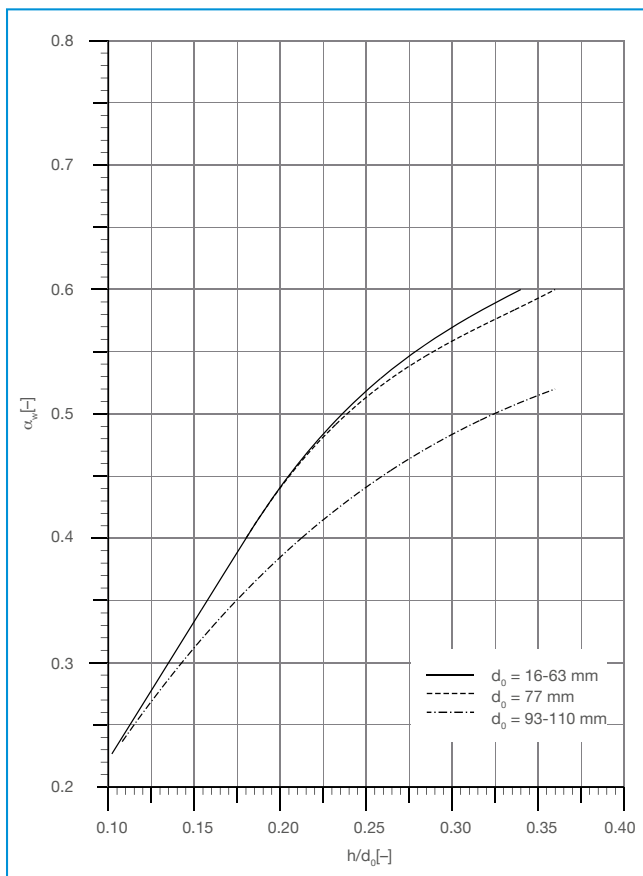

Si 6301 coefficient of discharge α_w depending on h/d_0 for liquid

- h = Lift [mm]
- d_0 = Flow diameter of the selected safety valve [mm]
- h/d_0 = Lift / Flow diameter ratio
- p_b = Absolute back pressure [bar a]
- p_0 = Absolute relieving pressure [bar a]
- p_b/p_0 = Absolute back pressure/absolute relieving pressure ratio
- α_w = Coefficient of discharge acc. to AD 2000-Merkblatt A2
- q_m = Required mass flow [kg/hr]
- q_{mc} = Certified mass flow [kg/hr]

Si 6301

Material code

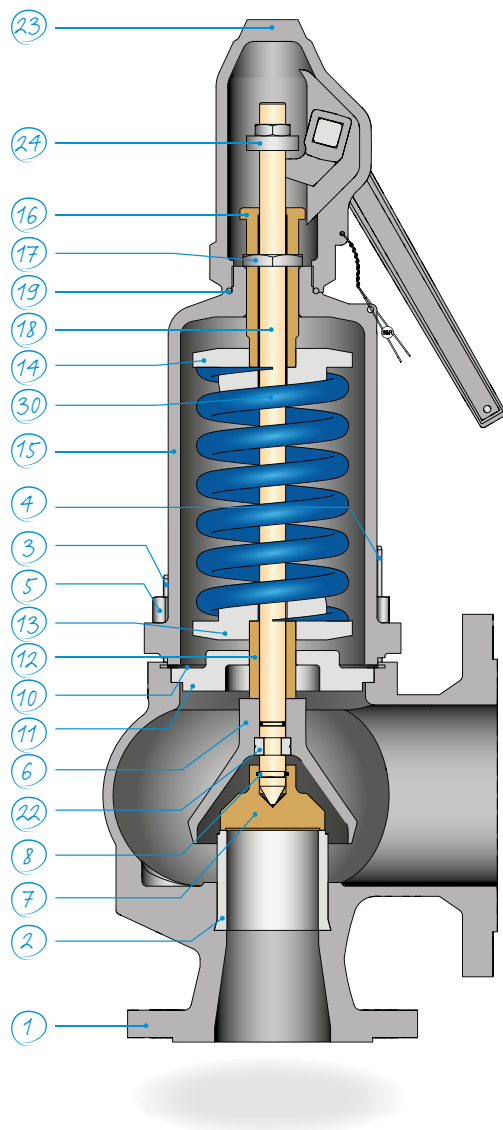

Material code	05	
Temperature application range	-10 °C to +300 °C	
Part	Name	Material
1	Body	EN-GJL-250 / 5.1301 GG25 / 0.6025 / EN-JL 1040
2	Seat bushing	1.4122
3	Stud, short	5.6
4	Stud, long	5.6
5	Hexagon nut	5
6	Disc holder	0.7040
7	Disc ³⁾	1.4122
8	Disc retainer	1.4571
10	Flat gasket	1.4401 / graphite
11	Intermediate cover ¹⁾	1.4122 1.4059
12	Pressure sleeve	1.4122
13	Spring washer, bottom	1.0038
14	Spring washer, top	1.0038
15	Bonnet	EN-GJL-250 / 5.1301 GG25 / 0.6025 / EN-JL 1040
16	Adjusting screw	1.4104
17	Lock nut	5
18	Spindle	1.4021
19	Flat gasket	1.4401 / graphite
22	Pressure ring	1.4122
23	Packed lifting lever (cap) ²⁾	0.7040
24	Lifting nut	1.4021
30	Spring ⁴⁾	1.1200 1.8159

¹⁾ Intermediate cover for DN 80 made from 1.4122, above that made from 1.4059

²⁾ Packed lifting lever (cap) from DN 150 flanged

³⁾ Disc material may be upgraded to stellated 1.4571 upon request for safety valves in saturated steam service

⁴⁾ The spring material selection depends on the valve size and set pressure.

IMI Bopp & Reuther reserve the right to technical changes or application of higher quality materials without prior notice. The material design can be tailored to customer specifications at any time upon request.

Si 6301

Sizes, pressure ranges and dimensions

Size	DN _E	20	25	32	40	50	65 ⁴⁾	80	100	125	150
	DN _A	32	40	50	65 ⁴⁾	80	100	125	150	200	250
Flow diameter [mm] d ₀		16	20	25	32	40	50	63	77	93	110
Flow area [mm ²] A ₀		201	314	491	804	1257	1964	3117	4657	6793	9503
Min. set pressure [bar g]		0.45	0.45	0.45	0.45	0.45	0.45	0.45	0.45	0.45	0.45
Max. set pressure ¹⁾ [bar g]		16	16	16	16	16	16	16	16	12.5	10
Max. back pressure [bar g]		4	4	4	4	4	4	4	4	3	2.5
Inlet flange DIN EN ²⁾		PN 10									
		PN 16									
Outlet flange DIN EN ²⁾		PN 10									
		PN 16									
Centre to face dimension S1 [mm]		85	95	100	115	125	140	155	175	215	225
Centre to face dimension S2 [mm]		95	105	110	130	145	150	170	180	220	245
Height H1 [mm]		355	405	430	510	565	675	725	825	875	1020
Drain size E ³⁾		G¼	G¼	G¼	G¼	G¼	G¾	G¾	G¾	G½	G1/2
Weight [kg]		8	10	13	19	25	37	50	74	95	140

¹⁾ Stated values are maximum values corresponding to the spring forces. The component strength may need to be reviewed depending on the material and temperature.

²⁾ Flanges PN 10/16 acc. to DIN EN 1092-2; flange facing Type B1

³⁾ Drain E is only drilled into the body if condensate formation is to be expected.

⁴⁾ 4-hole flange drilling for DN 65 PN 10/16

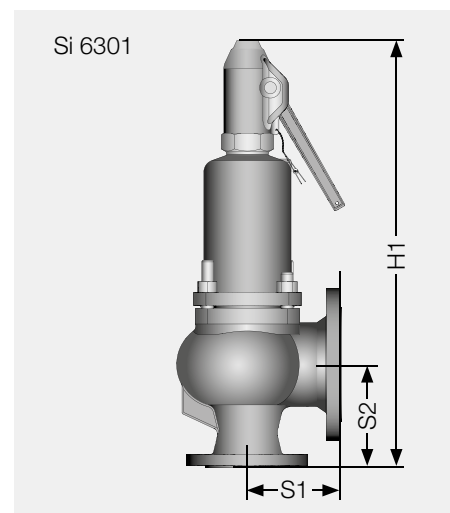

Si 4302

Features

The state-of-the-art IMI Bopp & Reuther medium-pressure safety valve:

- > Cost-effective semi nozzle body design with seat bushing
- > Developed in modular design with other series
- > Reliable function with ideal capacity
- > Inner parts made from stainless steel (except for spring and spring washer)

Inlet sizes

DN 20 to DN 200

Inlet pressure rating

PN 10 to PN 40

Set pressures

0.1 bar g to 40 bar g

Temperature range

-270 °C to + 450 °C

Overpressure

Vapours / gases	5%
Liquids	10%

Blow down

Vapours / gases	10%
Liquids	20%

Allowable built-up back pressure without bellows

20% of the set pressure

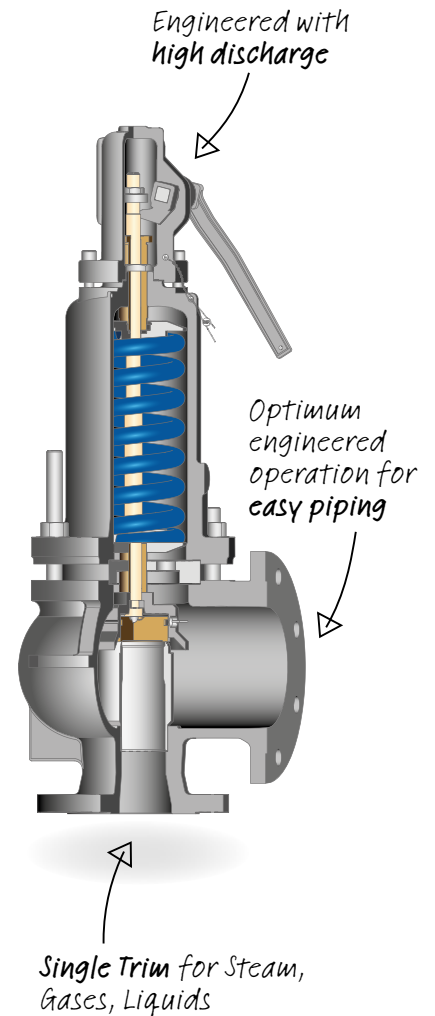

Applications

- > For vapours, gases and liquids
- > Protection of pressure vessels
- > Protection of heat exchangers
- > Protection of system components
- > Suitable for all industrial applications
- > Chemical industry
- > Petrochemical industry
- > Technical gases
- > Cooling and oxygen applications
- > Power generation and power supply
- > Steam boiler up to PN 40

Approvals and standards

EC type examination

- Pressure Equipment Directive 97 / 23 / EC
- DIN EN ISO 4126-1
- AD 2000-Merkblatt A2
- VdTÜV Merkblatt "Sicherheitsventil 100"

VdTÜV type approval acc. to

TÜV.SV.13 -1094.d₀.D / G / F.α_w.p

IMI Bopp & Reuther will not renew the existing VdTÜV type approvals. The requirements by VdTÜV and applicable standards are completely considered by the EC type examination.

The design, manufacture, testing and labelling meet the requirements of DIN EN ISO 4126-7, DIN EN 12266-1 / -2 (insofar as applicable to safety valves), DIN EN 1092 parts I and II Flanges, AD 2000-Merkblatt A4, AD 2000-Merkblatt HP0, technical rules for steam boiler TRD 110, TRD 421

Si 4302

Type code

Type code				Order example
1	Series	Si 4	Safety valve for high capacities	Si 4
2	Design	1	Conventional, open bonnet	4
		3	Conventional, closed bonnet	
		4	Bellows, closed bonnet	
		5	Bellows, open bonnet	
3	Characteristic	0	High capacity "High Flow"	0
4	Pressure class	2	Up to PN 40	2
5	Cap	G	Gastight cap	A
		GB	Gastight cap with test gag	
		A	Packed lifting lever	
		AB	Packed lifting lever with test gag	
		AK	Pneumatic actuator	
6	Material code	00	GP240GH / 1.0619	04
		04	GX5CrNiMo19-11-2 / 1.4408	
7	Options	.09	Locking sleeve (government ring)	.59
		.11t	Disc with soft seal PTFE	
		.14a	Lift indication with inductive proximity switch in the cap	
		.14b	Lift indication with inductive proximity switch in the auxiliary housing	
		.14c	Lift indication with inductive proximity switch for exposed spindle with actuator AK	
		.15	Bonnet spacer for high and low temperatures	
		.18	Heating jacket	
		.25	Block body design	
		.28	Oil and grease free	
		.32	Purge connection	
		.35	Lift restriction ring	
		.38	Vibration damper	
		.57	Weight loading	
.59	Stellited disc			
.60	Stellited seat			

Type ►	Si 4402 A 04 .59
Please state ►	Set pressure 18 bar g
	Fluid temp. 20°C
	Fluid and State Air, Gas
	Inlet DN 50, PN 40, B1
	Outlet DN 80, PN 16, B1
	Flow diameter 42 mm
	Approval 97 / 23 / EG (CE)

Si 4302

Coefficients of discharge

Fluid group	Inlet size	Flow diameter	$h/d_0 \geq$	$p_b/p_0 \leq$	α_w
Vapours / gases (D / G)	DN 20 to DN 200	17 mm to 156 mm	0.33	0.2	0.81
Liquids (F)	DN 20 to DN 200	17 mm to 156 mm	0.33	-	0.57

The coefficient of discharge for gases / vapours in a pressure ratio of $p_b/p_0 > 0.2$ is shown in the diagram below.

The capacity of the selected safety valves can be adjusted to the required capacity by reducing the lift, thus reducing undesirable extra performance. The following applies:

$\alpha_{w(\text{reduced})} = \alpha_w \times q_m/q_{mc}$. The required ratio h/d_0 is shown in the diagram below, and the reduced lift calculated with $h_{(\text{reduced})} = d_0 \times (h/d_0)$.

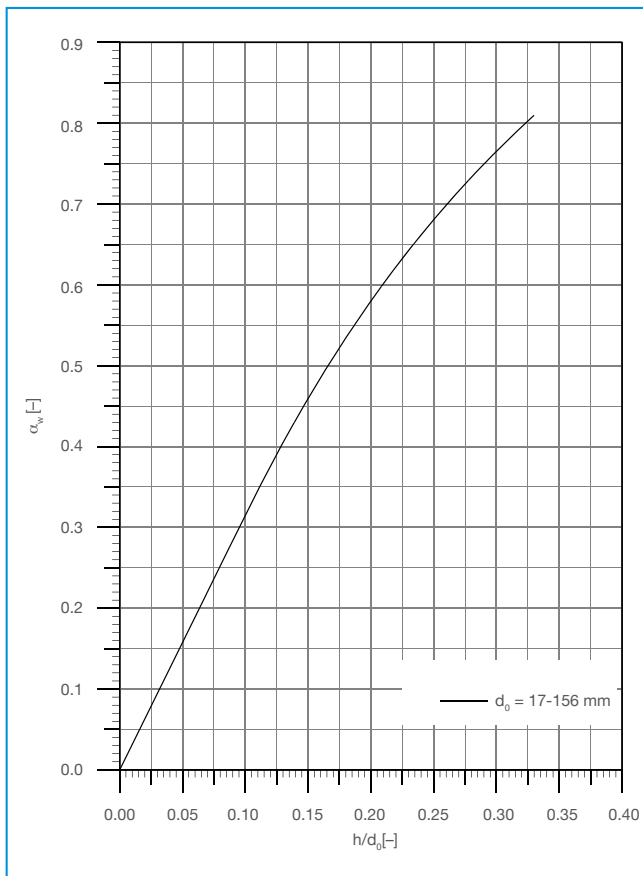

Si 4302 coefficient of discharge α_w depending on h/d_0 for gases and vapours

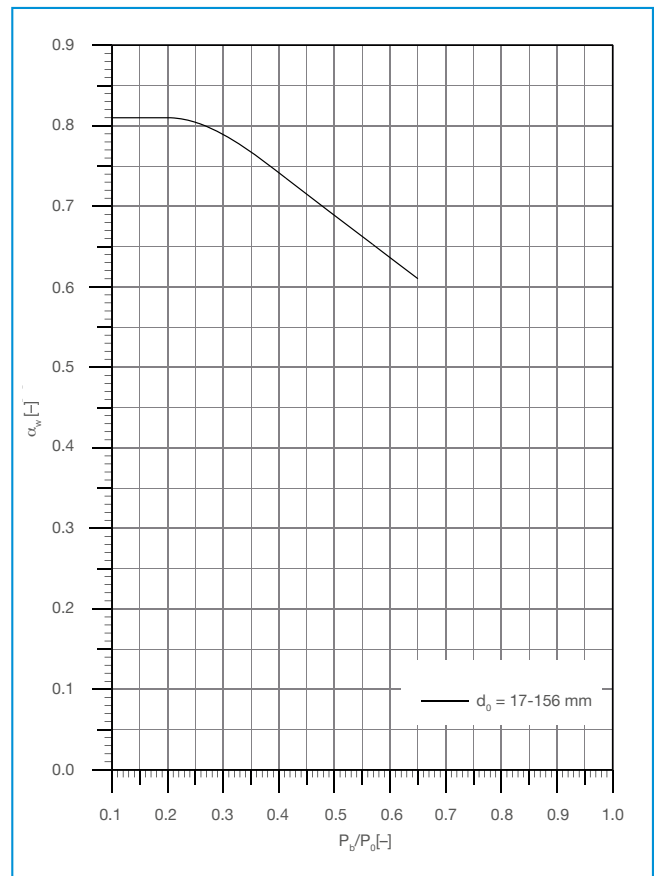

Si 4302 coefficient of discharge α_w depending on p_b/p_0 for gases and vapours

Si 4302

Sample size calculation for a safety valve in gas service acc. to DIN EN ISO 4126-7:

Fluid
air

Temperature T_0
20 °C = 293.15 K

Isentropic exponent k
1.4

Molar mass M
29.0 kg / kmol

Compressibility factor Z
1.0

Set pressure
1.5 bar g

Relieving pressure p_0 at 10% accumulation
(1.5 x 1.1) + 1 = 2.65 bar a

Back pressure p_b
atmospheric

Required capacity q_m
6.000 kg / hr

$p_b/p_0 = 0.377$ can be used to derive the coefficient of discharge $K_{dr} = 0.757$ from the diagram "Si 4302 coefficient of discharge α_w depending on p_b/p_0 for gases and vapours". (α_w is equal K_{dr})

As the condition for critical flow

$$\frac{p_b}{p_0} \leq \left(\frac{2}{k+1}\right)^{\frac{k}{k-1}} \text{ is met in the example, the following applies: } A = \frac{q_m}{p_0 C K_{dr} \sqrt{\frac{M}{Z T_0}}}$$

With $C = 3.948 \sqrt{k \left(\frac{2}{k+1}\right)^{\frac{k+1}{k-1}}} = 2.703$, is

$$A = \frac{6000}{2.65 \times 2.703 \times 0.757 \sqrt{\frac{29}{1 \times 293.15}}} = 3,518.1 \text{ mm}^2, \text{ is the required flow area.}$$

With a flow area of $A_0 = 4902 \text{ mm}^2$, the safety valve Si 4302 A 00, DN 100 x 150, PN 10 x 10, d_0 79.0 mm is suitable for this application (see page 18 for size range).

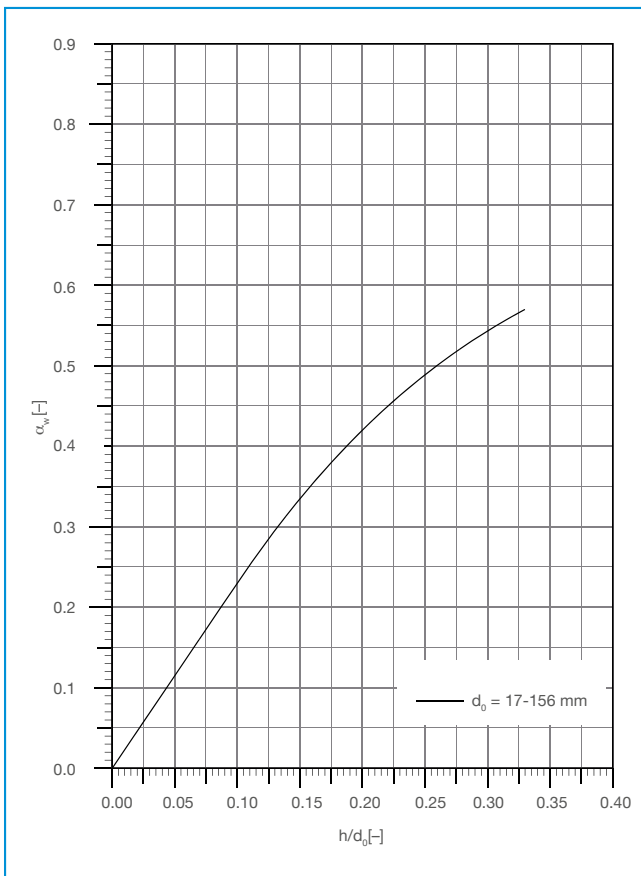

The coefficients of discharge K_{dr} acc. to DIN EN ISO 4126-1 for this valve series are identical with above coefficients of discharge α_w and the values in the diagrams.

- h = Lift [mm]
- d_0 = Flow diameter of the selected safety valve [mm]
- h/d_0 = Lift/Flow diameter ratio
- p_b = Absolute back pressure [bar a]
- p_0 = Absolute relieving pressure [bar a]
- p_b/p_0 = Absolute back pressure/absolute relieving pressure ratio
- α_w = Coefficient of discharge acc. to AD 2000-Merkblatt A2
- q_m = Required mass flow [kg/hr]
- q_{mc} = Certified mass flow [kg/hr]

Si 4302 coefficient of discharge α_w depending on p_b/p_0 for liquid

Si 4302

Material code

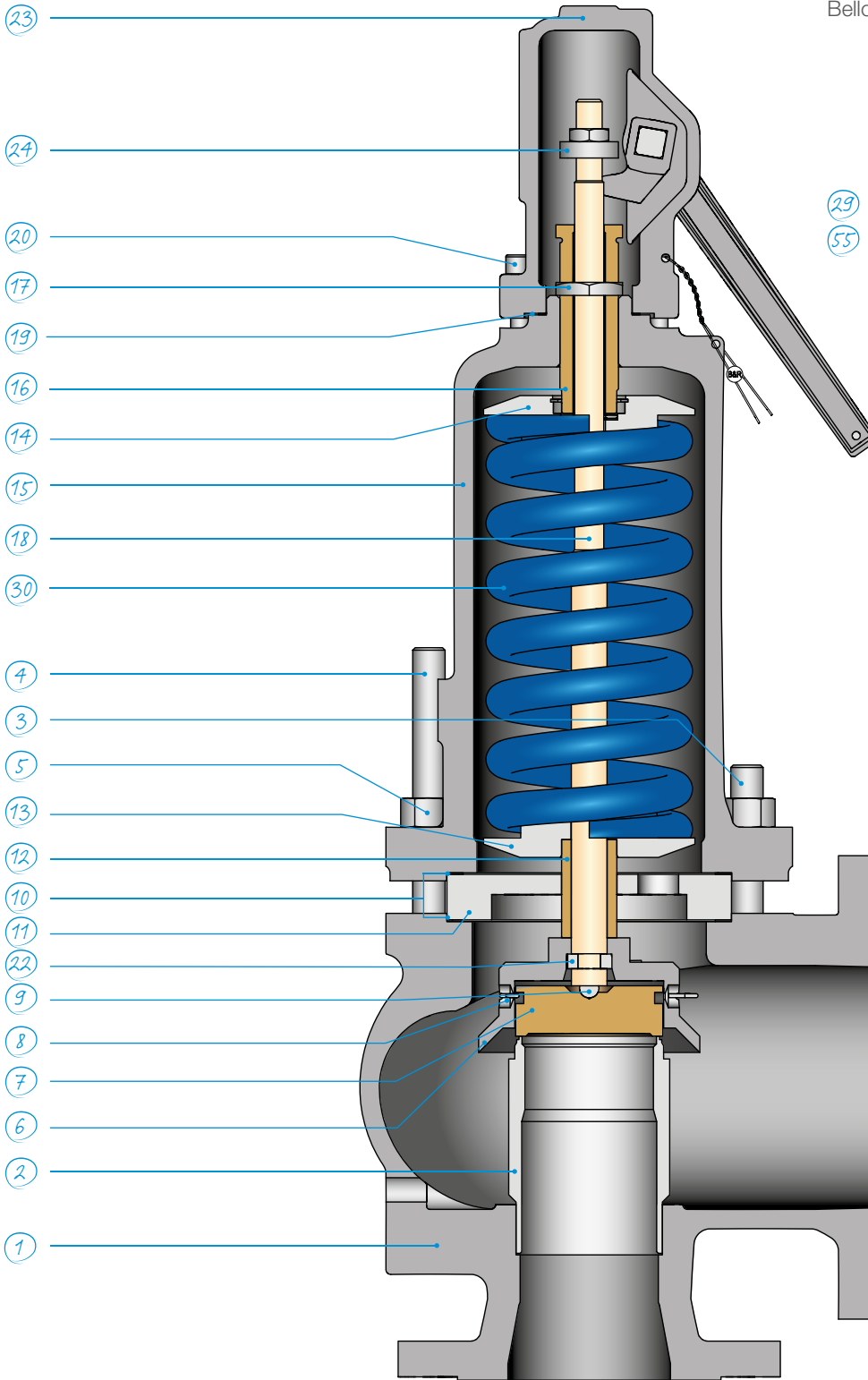

Bellows design Si 4402

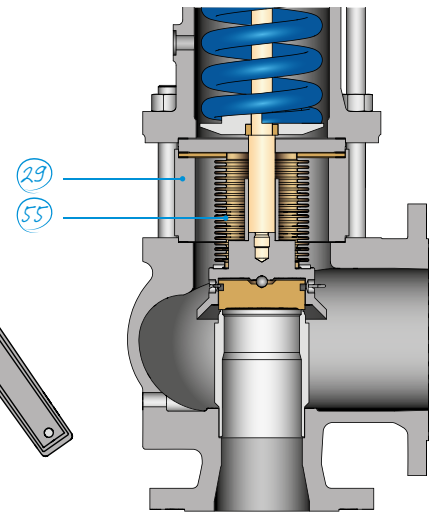

Si 4302

Material code		00	04
Temperature application range		-10 °C to +450 °C ¹⁾	-200 °C to +400 °C ²⁾
Part	Name	Spare part	Material
1	Body		1.0619 / 1.4408
2	Seat bushing		1.4122 / 1.4571
3	Stud, short		1.1181 / A4-70
4	Stud, long		1.1181 / A4-70
5	Hexagon nut		04 / A4-70
6	Disc holder		1.4021 / 1.4571
7	Disc	*2, 3	1.4571 / 1.4571
8	Disc retainer		1.4571 / 1.4571
9	Ball		Stainless steel / Ceramic
10	Flat gasket	*1, 2, 3	1.4401 / graphite / 1.4401 / graphite
11	Intermediate cover		1.4122 / 1.4571
12	Pressure sleeve		1.4122 / 1.4571
13	Spring washer, bottom		1.0460 / 1.4571
14	Spring washer, top		1.0460 / 1.4571
15	Bonnet		1.0619 / 1.4408
16	Adjusting screw		1.4571 / 1.4571
17	Lock nut		1.4104 / 1.4571
18	Spindle		1.4021 / 1.4571
19	Flat gasket	*1, 2, 3	1.4401 / graphite / 1.4401 / graphite
20	Hex socket head screw		8.8 / A4-70
22	Pressure ring		1.4571 / 1.4571
23	Packed lifting lever (cap)		1.0619 / 1.4408
24	Lifting nut		1.4404 / 1.4571
29	Bonnet spacer		1.0619 / 1.4408
30	Spring ³⁾	*3	1.1200 / 1.4310 1.8159 / 1.8159, chem. nickel plated
55	Bellows	*3	1.4571 / 1.4571

¹⁾ Material may be used in temperatures down to -85 °C if the specification of AD 2000-Merkblatt W10 is complied with.

²⁾ Material may be used in temperatures down to -273 °C if the specification of AD 2000-Merkblatt W10 is complied with.

³⁾ The spring material selection depends on the valve size and set pressure as well as the temperature. Other spring materials are available for special operating conditions, e.g. temperatures > 400 °C or < -170 °C, and if the customer specifies this.

Spare Parts:

*1 For start-up

*2 For 2 years of operation

*3 After several years of operating

IMI Bopp & Reuther reserve the right to technical changes or application of higher quality materials without prior notice. The material design can be tailored to customer specifications at any time upon request.

Si 4302

Sizes, pressure ranges and dimensions

Size	DN _E	20	25	32	40	40	40	50	65 ³⁾	80	80	80	100	125	150	150	200	200		
	DN _A	32	40	50	50	65 ³⁾	80	80	100	100	125	150	150	200	200	250	250	300		
Flow diameter [mm] d ₀		17	22	27.5	27.5	35	35	42	52	52	65	65	79	93	93	112	125	156		
Flow area [mm ²] A ₀		227	380	594	594	962	962	1385	2124	2124	3318	3318	4902	6793	6793	9852	12272	19113		
Min. set pressure [bar g]	Si 41 / Si 43	0.49	0.49	0.49	0.49	0.49	0.49	0.49	0.49	0.49	0.49	0.49	0.49	0.49	0.49	0.49	0.49	0.49		
	Si 4302.57 ¹⁾	0.25	0.2	0.1	0.1	0.13	0.13	0.13	0.16	0.16	0.11	0.11	0.13	0.15	0.18	0.15	0.16	0.15		
	Si 44 / Si 45	1.5	1.5	1.5	1.5	1.5	1.5	1.5	1.5	1.5	1.5	1.5	1.5	1.5	1.5	1.5	1.5	1.5		
Max. set pressure ¹⁾ [bar g]		40	40	40	40	32	32	32	32	32	25	25	20	20	20	25	15	14		
Max. back pressure ²⁾ [bar g]		16	16	16	16	16	16	16	16	16	10	10	10	7	7	7	4	4		
Inlet flange DIN EN ⁴⁾	PN 10 - 40 (with flange thickness as per PN 40)												PN 10/16 (DN 200 PN 16 with flange thickness as per PN 25)							
							PN 25 / 40						PN 25							
Outlet flange DIN EN ⁴⁾	PN 10 - 40				PN 10/16														PN 10	
Centre to face dimension S1 [mm]	85	95	100	100	115	115	125	140	140	155	155	175	215	215	225	240	265			
Centre to face dimension S2 [mm]	95	105	110	110	130	130	145	150	150	170	170	180	220	220	245	270	290			
Height H1 [mm]	410	425	435	435	522	522	576	690	690	740	740	840	1030	1030	1195	1225	1320			
Height H2 [mm]	470	480	480	480	572	572	626	750	750	810	810	920	1135	1135	1325	1355	240			
Additional height H3 f. actuator AK [mm]	222	222	222	222	310	310	310	267	267	267	267	267	394	394	240	240	240			
Drain size E ⁵⁾	G ¹ / ₄	G ¹ / ₄	G ¹ / ₄	G ¹ / ₄	G ¹ / ₄	G ¹ / ₄	G ¹ / ₄	G ³ / ₈	G ³ / ₈	G ³ / ₈	G ³ / ₈	G ³ / ₈	G ³ / ₈	G ¹ / ₂	G ¹ / ₂	G ¹ / ₂	G ³ / ₄	G ³ / ₄		
Weight Si 41/43 [kg]	9	12	14	14.5	19	21	27	40	43	55	58	84	104	108	148	183	240			
Weight Si 44/45 and Si 41/43.15 [kg]	11	14	17	17.5	22	25	31	44	47	60	63	92	112	122	178	213	270			
Additional weight actuator AK [kg]	12	12	12	12	37	37	37	37	37	37	37	37	37	76	76	80	80	80		

¹⁾ Set pressure if the direct weight load option .57 is used.

²⁾ Stated values are maximum values corresponding to the spring forces. The component strength

may need to be reviewed, and a suitable pressure rating selected, depending on the material and temperature.

³⁾ 4-hole flange drilling with DN 65 PN 10/16

⁴⁾ Flanges PN 10 - 40 acc. to DIN EN 1092-2; facing type B1

⁵⁾ Drain E is only drilled into the body if condensate formation is to be expected.

Si 4302

Si 4302
Si 4102

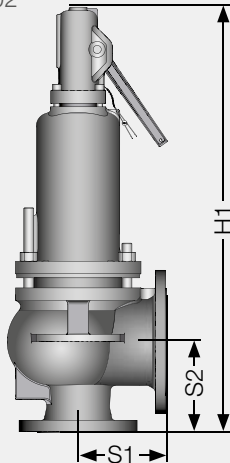

Si 4402
Si 4502

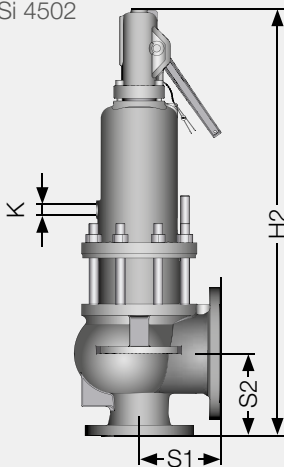

Actuator AK

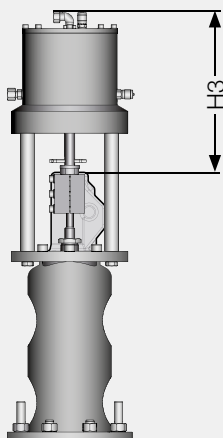

Support brackets

Size DN _E × DN _A	A	B	C	D	E	L	Support bracket thickness	Number of screws
40 x 65	180	84	134	60	150	14	10	4 x M 12
40 x 80	180	84	134	60	150	14	10	4 x M 12
50 x 80	210	93	160	65	175	14	12	4 x M 12
65 x 100	245	94	196	65	210	14	12	4 x M 12
80 x 100	245	94	196	65	210	14	12	4 x M 12
80 x 125	300	115	240	85	265	18	15	4 x M 16
80 x 150	320	150	280	125	290	18	15	4 x M 16
100 x 150	320	150	280	125	290	18	15	4 x M 16
125 x 200	365	120	300	85	325	18	15	4 x M 16
150 x 200	365	120	300	85	325	18	15	4 x M 16
150 x 250	415	150	360	115	375	18	15	4 x M 16
200 x 250	455	180	400	145	415	18	15	4 x M 16
200 x 300	510	180	450	145	465	22	20	4 x M 20

Dimensions in mm

The height from the inlet to the lower edge of the support bracket is identical with the centre to face dimension S2.

Support brackets will only be drilled if specified by the customer.

The bonnet for bellows seal design is provided with the test connection K. K up to DN 50 x 80 – G1/4", above G3/8".

Support brackets

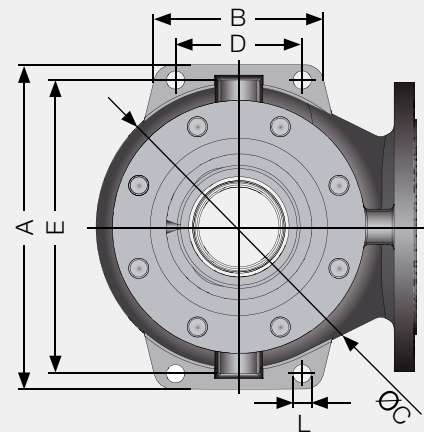

Si 6303 / Si 6304 / Si 6305

Features

The proven quality IMI Bopp & Reuther high-pressure safety valve:

- > A reliable design with solid inlet nozzle, screwed in and welded
- > Available in material designs for high as well as low temperatures
- > With a great variety of sizes and options

Inlet sizes

DN 25 to DN 400

Inlet pressure rating

PN 10 to PN 400

Set pressures

0.45 bar g to 250 bar g

Temperature range

-270 °C to + 550 °C

Overpressure

Vapours / gases	5%
Liquids	10%

Blow down

Vapours / gases	10%
Liquids	20%

Allowable built-up back pressure

15% of the set pressure

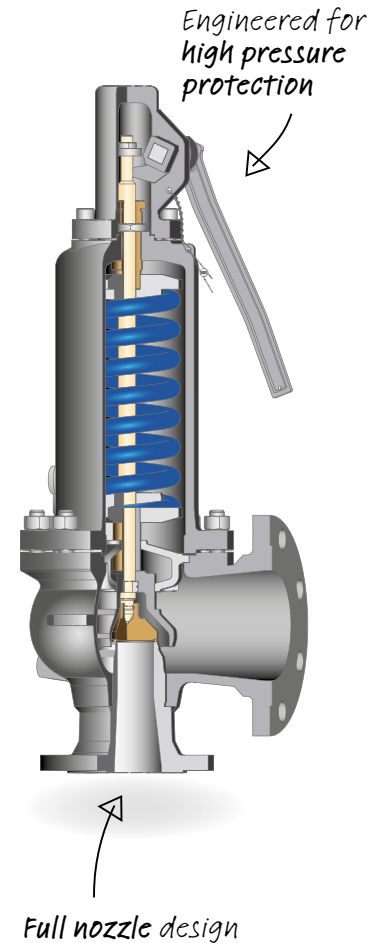

Applications

- > For vapours, gases and liquids
- > Protection of system components
- > Steam boiler
- > Air separator
- > Power plants and industrial steam generation
- > Paper factories
- > High-pressure chemical processes

Approvals and standards

EC type examination

- Pressure Equipment Directive 97 / 23 / EC
- DIN EN ISO 4126-1
- AD 2000-Merkblatt A2
- VdTÜV Merkblatt "Sicherheitsventil 100"

VdTÜV type approval acc. to

TÜV.SV.12-1134.d₀.D/G/F.α_w.p

TÜV.SV.13-701.d₀.F.α_w.p

IMI Bopp & Reuther will not renew the existing VdTÜV type approvals. The requirements by VdTÜV and applicable standards are completely considered by the EC type examination.

The design, manufacture, testing and labelling meet the requirements of DIN EN ISO 4126-7, DIN EN 12266-1 / -2 (insofar as applicable to safety valves), DIN EN 1092 parts I and II Flanges, AD 2000-Merkblatt A4, AD 2000-Merkblatt HP0, technical rules for steam boiler TRD 110, TRD 421

Si 6303 / Si 6304 / Si 6305

Type code

Type code				Order example
1	Series	Si 6	DIN/EN Full lift valve	Si 6
2	Design	1	Conventional, open bonnet	1
		3	Conventional, closed bonnet	
		4	Bellows, closed bonnet	
		5	Bellows, open bonnet	
3	Characteristic	0	High capacity "High Flow"	0
		1	Proportional acting "Proportional Flow"	
4	Pressure class	3	max. PN 160 (up to 62 bar g)	4
		4	max. PN 160 (up to 95 bar g)	
		5	max. PN 400	
5	Cap	G	Gastight cap	AB
		GB	Gastight cap with test gag	
		A	Packed lifting lever	
		AB	Packed lifting lever with test gag	
		AK	Pneumatic actuator	
6	Material code ²⁾	00	GP240GH / 1.0619	00
		01	G17CrMo5-5 / 1.7357	
		04	GX5CrNiMo19-11-2 / 1.4408	
7	Options	.09	Locking sleeve (government ring)	.22a .60
		.11a	Disc with soft seal EPDM (pressure class 3 only)	
		.14a	Lift indication with inductive proximity switch in the cap	
		.14b	Lift indication with inductive proximity switch in the auxiliary housing	
		.14c	Lift indication with inductive proximity switch for exposed spindle with actuator AK	
		.15	Bonnet spacer for high and low temperatures	
		.18	Heating jacket	
		.22a ¹⁾	Weld end at inlet	
		.22b	Weld end at outlet	
		.25	Block body design	
		.28	Oil and grease free	
		.32	Purge connection	
		.35	Lift restriction ring	
		.38	Vibration damper	
		.59	Stellited disc	
.60	Stellited seat			

¹⁾ For valves with weld ends, please state the pipe's outer diameter, wall thickness and joint type code in the order. See page 39 for information on standard dimensions.

²⁾ The standard materials of the material codes can be changed by selecting trim codes. Please see page 44 for information on the trim codes T1, T2, T3.

Type ►	Si 6104 AB 00 .22a .60
Please state ►	Set pressure 38 bar g
	Fluid temp. 360 °C
	Fluid and State Superheated steam, Steam
	Inlet DN 100, weld end
	Weld end dimensions ¹⁾ 117 x 5.6 mm
	Outlet DN 150, PN 40, B1
	Flow diameter 63 mm
	Approval 97 / 23 / EG (CE)

Si 6303 / Si 6304 / Si 6305

Coefficients of discharge

Fluid group	Inlet size	Flow diameter	$h/d_0 \geq$	$p_b/p_0 \leq$	α_w
Vapours / gases (D / G)	DN 25 to DN 150	16 mm to 77 mm	0.34	0.25	0.78
	DN 125 to DN 200	86 mm to 110 mm	0.36	0.25	0.78
	DN 200 to DN 300	117 mm to 180 mm	0.36	0.3	0.74
	DN 300 to DN 400	200 mm to 280 mm	0.36	0.3	0.71
Liquids (F)	DN 25 to DN 100	16 mm to 70 mm	0.34	-	0.6
	DN 100 to DN 150	77 mm	0.36	-	0.6
	DN 125 to DN 200	86 mm to 125 mm	0.36	-	0.52

The coefficient of discharge for gases/vapours in a pressure ratio of $p_b/p_0 > 0.25$ and/or $p_b/p_0 > 0.3$ is shown in the diagram below.

The capacity of the selected safety valves can be adjusted to the required capacity by reducing the lift, thus reducing undesirable extra performance. The following applies:

$\alpha_{w(\text{reduced})} = \alpha_w \times q_m/q_{mc}$. The required ratio h/d_0 is shown in the diagram below, and the reduced lift calculated with $h_{(\text{reduced})} = d_0 \times (h/d_0)$.

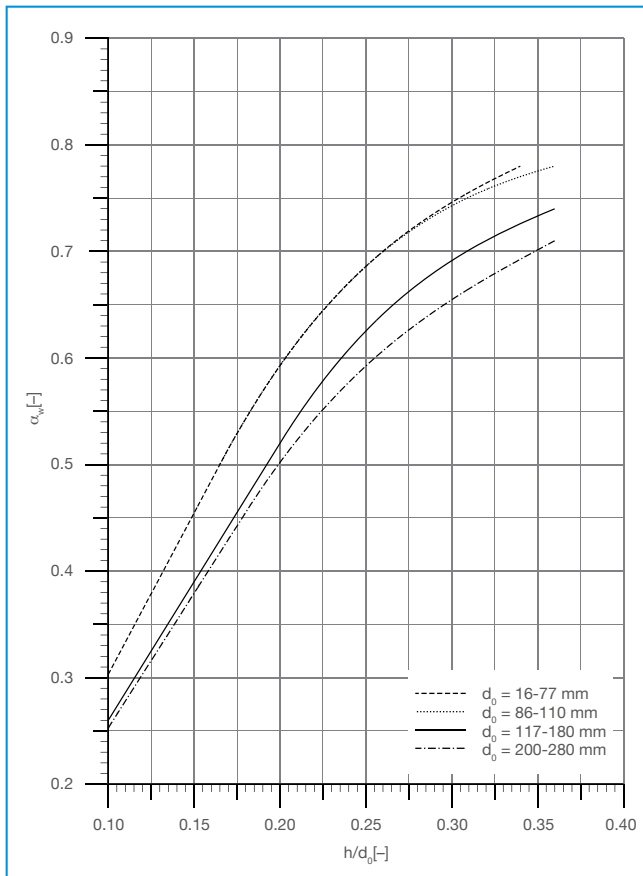

Si6303/Si6304/Si6305 coefficient of discharge α_w depending on h/d_0 for gases and vapours

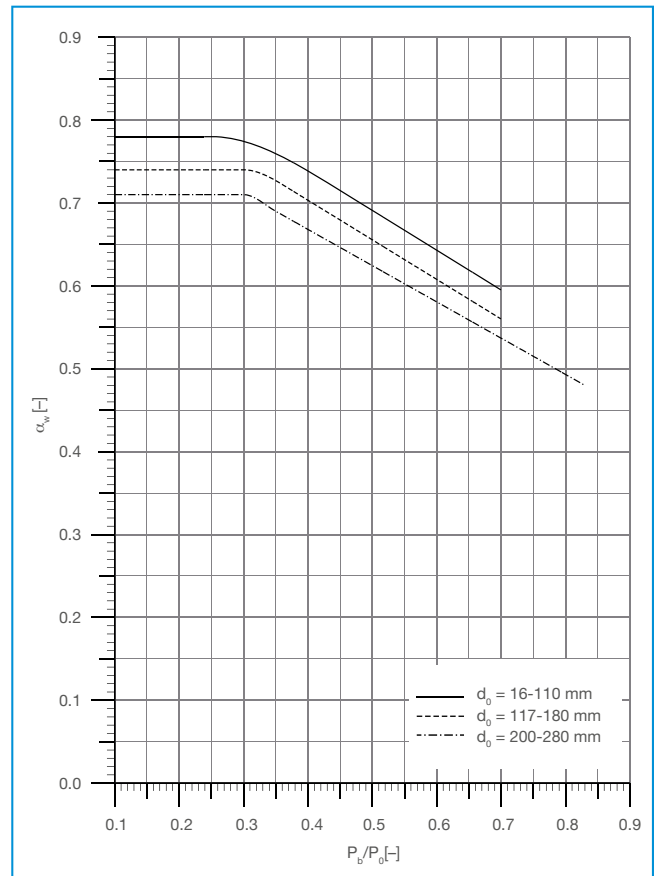

Si6303/Si6304/Si6305 coefficient of discharge α_w depending on p_b/p_0 for gases and vapours

Si 6303 / Si 6304 / Si 6305

Sample size calculation for a safety valve in liquid service acc. to DIN EN ISO 4126-7:

Fluid
oil

Density
700 kg/m³

Temperature T₀
56 °C = 329 K

Set pressure
48.0 bar g

Relieving pressure p₀ at 10% accumulation
(48 x 1.1) + 1 = 53.8 bar a

Back pressure p_b
15 bar a

Required capacity q_m
51.000 kg/hr

For rather small sizes, the coefficient of discharge K_{dr} = 0.6 can be derived from the table on page 22 for liquids.

As the viscosity is negligible in this example, k_v = 1.0 can be used in the calculation.

$$A = \frac{q_m}{1.61 K_{dr} k_v \sqrt{\frac{v}{p_0 - p_b}}}$$

is the required flow area.

The specific volume v = 1/density = 0.0014285

$$A = \frac{51000}{1.61 \times 0.6 \times 1.0 \sqrt{\frac{0.0014285}{53.8 - 15}}} = 320.35 \text{ mm}^2$$

With a flow area of A₀ = 491 mm², the safety valve Si 6303 G 00, DN 40 x 50, PN 63 x 16, d₀ 25.0 mm is suitable for this application (see page 26 for the size range).

The certified capacity q_{m,c} can be established as 78.146.9 kg/hr from above equation.

The lift can be restricted to reduce the undesirable extra performance (q_{m,c}/q_m) of 53%.

$\alpha_{w(\text{reduced})} = \alpha_w \times q_m / q_{m,c} = 0.6 \times 51.000 / 78.146.9 = 0.39$. The ratio h/d₀ can be derived from the diagram as 0.18, which makes the restricted lift h = 0.18 x 25 = 4.5 mm.

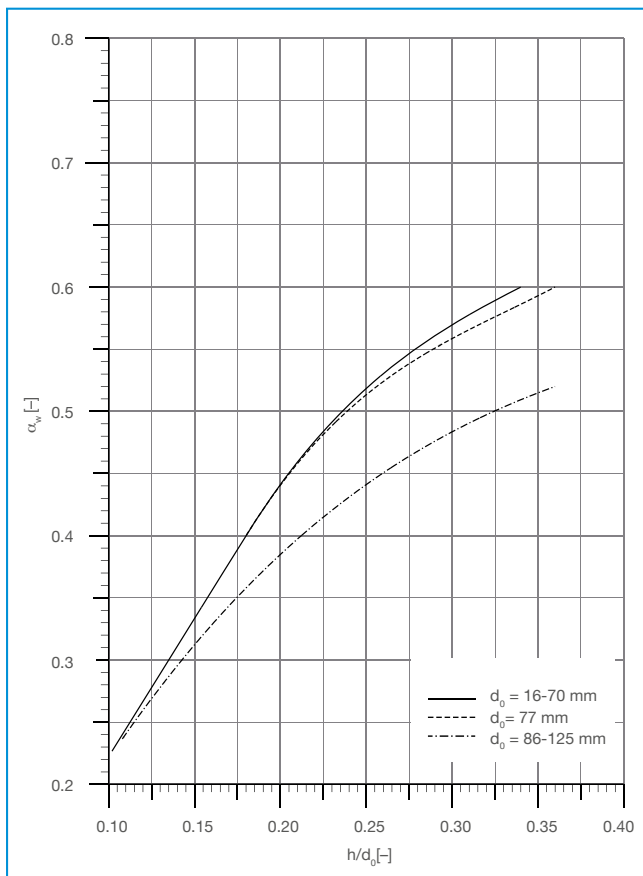

The coefficients of discharge K_{dr} acc. to DIN EN ISO 4126-1 in this series are identical with above coefficients of discharge α_w and the values in the diagrams.

- h = Lift [mm]
- d₀ = Flow diameter of the selected safety valve [mm]
- h/d₀ = Lift/Flow diameter ratio
- p_b = Absolute back pressure [bar a]
- p₀ = Absolute relieving pressure [bar a]
- p_b/p₀ = Absolute back pressure/absolute relieving pressure ratio
- α_w = Coefficient of discharge acc. to AD 2000-Merkblatt A2
- q_m = Required mass flow [kg/hr]
- q_{m,c} = Certified mass flow [kg/hr]

The safety valve type Si 6x13/Si 6x14/Si 6x15 is designed for liquid service with the specific requirement of a “proportional opening characteristic”. This specification is certified by a particular EC approval. With the lift / flow diameter ratio of h/d₀ > 0.16; the corresponding coefficient of discharge is α_w 0.36.

Si 6303/Si 6304/Si 6305 coefficient of discharge α_w depending on h/d₀ for Liquid

Si 6303

Material code

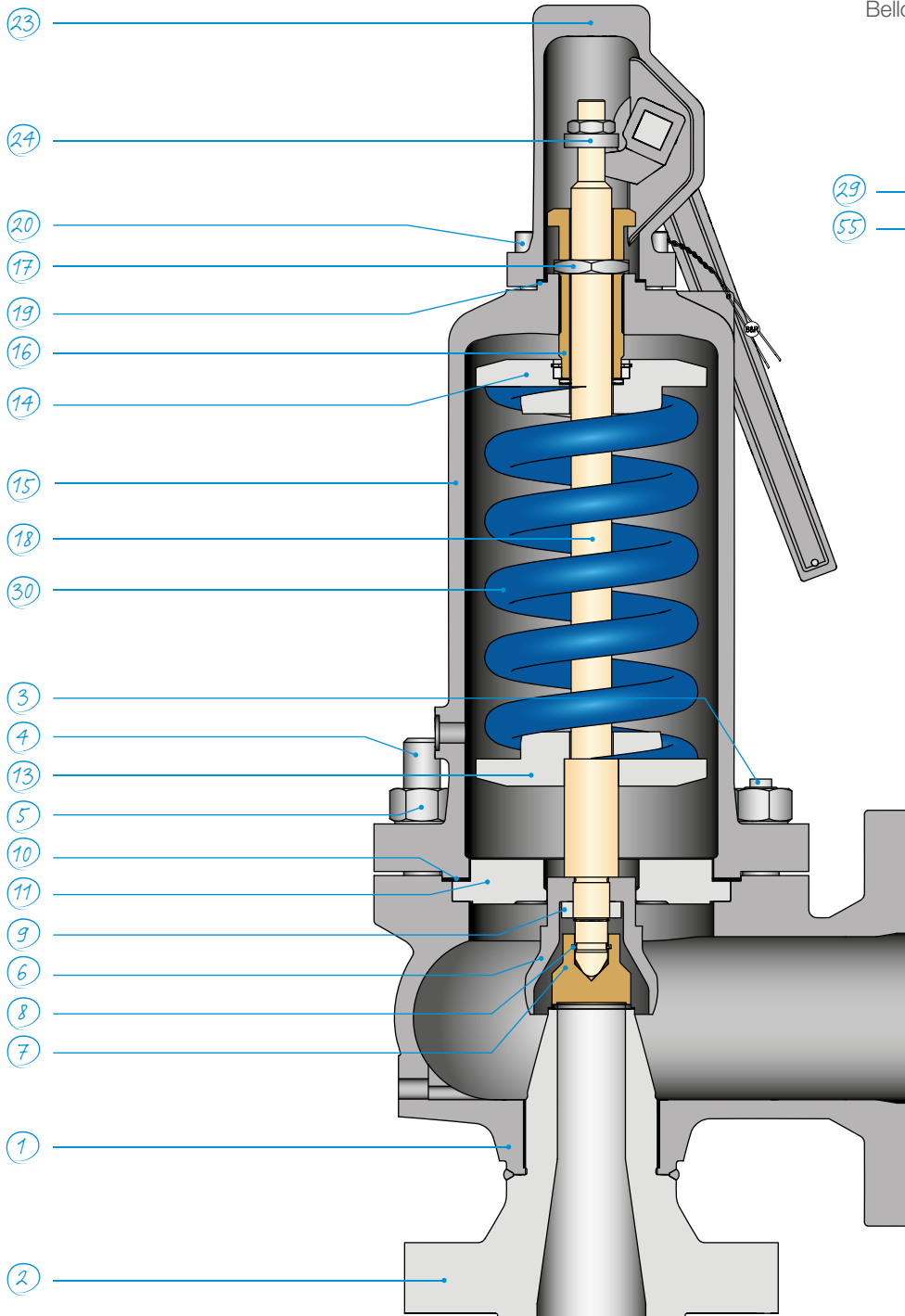

Bellows design Si 6403

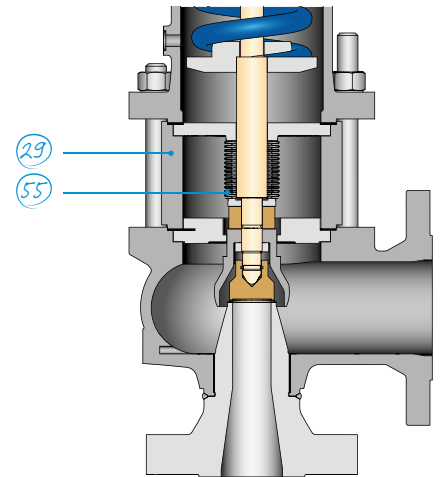

Si 6303

Material code			00	01	04
Temperature application range			-10 to +450 °C ¹⁾	Max. 550 °C	-200 to +400 °C ²⁾
Part	Name	Spare part	Material	Material	Material
1	Body		GP240GH / 1.0619	G17CrMo5-5 / 1.7357	GX5CrNi-Mo19-11-2 / 1.4408
2	Inlet nozzle ⁷⁾		1.0460 1.0619 Seat surface hard-faced with Stellite	1.7335 1.7357 Seat surface hard-faced with Stellite	1.4571 1.4408 Seat surface hard-faced with Stellite
3	Stud, short		1.7709	1.7709	A4-70
4	Stud, long		1.7709	1.7709	A4-70
5	Hexagon nut		04	04	04
6	Disc holder		1.0460 5.3106 / GGG-40	1.4571 1.4408	1.4571 1.4408
7	Disc	*2, 3	1.4122 Hardened	1.4122 Hardened	1.4571 Seat surface hard-faced with Stellite
8	Disc retainer		1.4571	1.4571	1.4571
9	Groove nut		1.4571	1.4571	1.4571
10	Flat gasket	*1, 2, 3	1.4401 / graphite	1.4401 / graphite	1.4401 / graphite
11	Intermediate cover ⁹⁾		1.4122	1.4122	1.4571 1.4408
13	Spring washer, bottom		1.0460	1.4571	1.4571
14	Spring washer, top		1.0460	1.4571	1.4571
15	Bonnet ^{4) 6)}		GP240GH / 1.0619	G17CrMo5-5 / 1.7357 ⁵⁾	GX5CrNi-Mo19-11-2 / 1.4408
16	Adjusting screw		1.4122	1.4571	1.4571
17	Lock nut		1.7258	1.7258	1.4571
18	Spindle		1.4122	1.4122	1.4571
19	Flat gasket	*1, 2, 3	1.4401 / graphite	1.4401 / graphite	1.4401 / graphite
20	Cylinder bolt		8.8	8.8	A4-70
23	Packed lifting lever (cap) ³⁾		1.0619	1.0619	1.4408
24	Lifting nut		1.4401	1.4401	1.4401
29	Bonnet spacer		1.0460	1.7335	1.4571
30	Spring ⁸⁾	*3	1.1200 1.8159	1.1200 1.8159	1.4310 1.8159, chem. nickel plated
55	Bellows	*3	1.4571	1.4571	1.4571

¹⁾ Material may be used in temperatures down to -85 °C if the specification of AD 2000-Merkblatt W10 is complied with.

²⁾ Material may be used in temperatures down to -273 °C if the specification of AD 2000-Merkblatt W10 is complied with.

³⁾ Packed lifting lever (cap) from DN 50 x 80 flanged

⁴⁾ Design Si 61 with open bonnet only for valves acc. to material code „00“ and „01“.

⁵⁾ Bonnet in GP240GH/1.0619 for valves Si 61 with open bonnet, Si 64 with bellows or with design option .15.

⁶⁾ Si 63 type valves with closed bonnet with design option .15 above 400 °C.

⁷⁾ Inlet nozzle up to seat ø 77 mm and with weld end option .22a is always manufactured in forging, flow diameter ø 93 mm and above in casting

⁸⁾ The spring material selection depends on the valve size and set pressure as well as the temperature. Other spring materials are available for special operating conditions, e.g. temperatures > 400 °C or < -170 °C, and if the customer specifies this.

⁹⁾ Intermediate cover for valves acc. to material code 00 and 01 up to DN 125 x 200 made from 1.4122, above this made from 1.4408.

Spare Parts:

*1 For start-up

*2 For 2 years of operation

*3 After several years of operation

All safety valves in pressure class 5 are equipped with a needle bearing between the adjusting screw and upper spring washer.

IMI Bopp & Reuther reserve the right to technical changes or application of higher quality materials without prior notice. The material design can be tailored to customer specifications at any time upon request.

Si 6303

Sizes, pressure ranges and dimensions

Size	DN _E	25	25	32	40	40	40	50	65	80	80	80	100	125	150	150	200	200	250	300	400
	DN _A	32	40	50	50	65	80	80	100	100	125	150	150	200	200	250	250	300	350	400	500
Flow diameter [mm] d ₀		16	20	25	25	32	32	40	50	50	63	63	77	93	93	110	125	155	180	220	280
Flow area [mm ²] A ₀		201	314	491	491	804	804	1257	1964	1964	3117	3117	4657	6793	6793	9503	12270	18870	25450	38010	61575
Min. set pressure [bar g]	Si 61/ Si 63	0.45	0.45	0.45	0.45	0.45	0.45	0.45	0.45	0.45	0.45	0.45	0.45	0.45	0.45	0.45	0.45	0.45	0.45	0.45	0.45
	Si 64/ Si 65	2.0	2.0	2.0	2.0	2.0	2.0	2.0	2.0	2.0	2.0	2.0	2.0	2.0	2.0	2.0	2.0	2.0	2.0	2.0	2.0
Max. set pressure ¹⁾ [bar g]		62	62	62	62	62	62	62	62	62	50	50	40	25	25	20	12.5	10	8	7	6
Max. back pressure ²⁾ [bar g]		25	24	24	24	24	24	24	24	24	20	20	15	10	10	8	5	4	2.5	2.5	1.25
Inlet flange DIN EN ⁴⁾		PN 10 - 40						PN 25/40										PN 10 - 40			
		PN 63																			
		PN 100																			
		PN 160																			
Outlet flange DIN EN ⁴⁾		PN 10/16/25																			
		PN 40																			
Centre to face dimension S1 [mm]		95	100	110	110	130	130	145	155	155	190	190	210	215	215	225	240	265	300	335	375
Centre to face dimension S2 [mm]		110	110	115	115	140	140	150	160	175	180	180	200	220	220	245	270	290	340	370	415
Height H1 [mm]		400	420	475	475	535	535	650	685	685	790	790	920	960	960	1020	1125	1210	1400	1480	1650
Height H2 [mm]		475	505	590	590	645	645	765	820	820	940	940	1040	1040	1040	1180	1295	1380	1580	1700	1835
Additional height H3 f. actuator AK [mm]		222	222	205	205	205	205	267	267	267	267	267	394	394	394	394	310	310	490	490	490
Drain size E ³⁾		G ¹ / ₄	G ¹ / ₄	G ¹ / ₄	G ¹ / ₄	G ¹ / ₄	G ¹ / ₄	G ¹ / ₄	G ³ / ₈	G ³ / ₈	G ³ / ₈	G ³ / ₈	G ³ / ₈	G ³ / ₈	G ¹ / ₂	G ¹ / ₂	G ¹ / ₂	G ³ / ₄	G ³ / ₄	G ³ / ₄	G ³ / ₄
Weight Si 61/63 [kg]		12	14	19	20	28	35	40	50	52	80	85	126	135	155	170	230	270	370	480	660
Weight Si 64/65 and Si 61/63.15 [kg]		15	17	22	24	32	39	44	55	57	88	93	140	165	185	200	270	320	325	550	745
Additional weight actuator AK [kg]		12	12	22	12	12	12	37	37	37	37	37	76	76	76	76	76	76	175	175	175

¹⁾ Stated pressures are maximum values corresponding to the spring forces. The component strength may need to be reviewed, and the suitable pressure rating selected, depending on the material and temperature.

²⁾ Or in accordance with the pressure rating at the outlet.
³⁾ Drain E is only drilled into the body if condensate formation is to be expected.

⁴⁾ Flanges PN 10 - 40 acc. to DIN E 1092 x 2; facing type B1, from PN 63 facing type B2

Si 6303

Si 6303
Si 6103

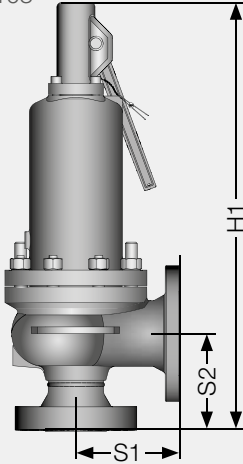

Si 6403
Si 6503

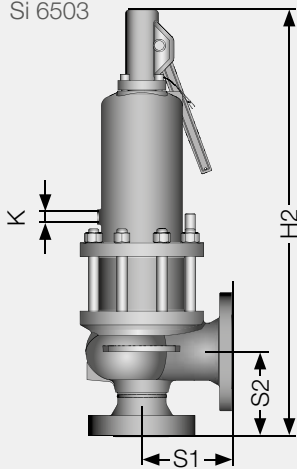

Actuator AK

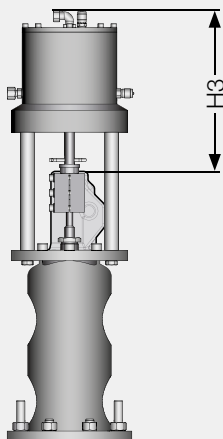

Support brackets

Size DN _E × DN _A	A	B	C	D	E	L	Support bracket thickness	Number of screws
40 x 65	186	93	140	70	156	14	12	4 x M 12
50 x 80	210	95	165	70	180	14	12	4 x M 12
65 x 100	250	95	205	70	220	14	12	4 x M 12
80 x 125	295	120	240	90	260	18	15	4 x M 16
100 x 150	320	120	265	90	285	18	15	4 x M 16
125 x 200	365	120	300	90	330	18	15	4 x M 16
150 x 250	415	150	360	120	380	18	15	4 x M 16
200 x 250	455	180	400	150	420	18	15	4 x M 16
200 x 300	510	180	450	150	470	23	20	4 x M 20
250 x 350	620	190	560	160	580	23	20	4 x M 20
300 x 400	695	210	600	180	655	23	20	4 x M 20
400 x 500	800	230	715	200	760	23	20	4 x M 20

Dimensions in mm

The height from the inlet to the lower edge of the support bracket is identical with the centre to face dimension S2.

Support brackets will only be drilled if specified by the customer.

The bonnet for bellows seal design is provided with the test connection K. K up to DN 50 x 80 – G $\frac{1}{4}$ " , above G $\frac{3}{8}$ ".

Support brackets

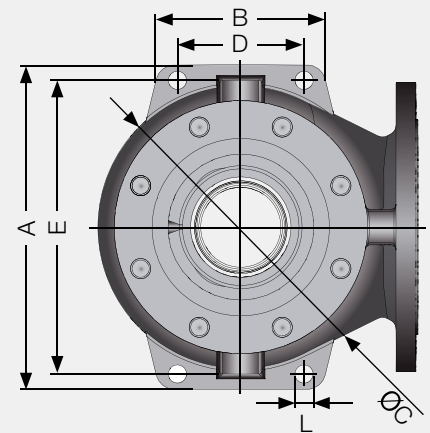

Si 6304

Material code

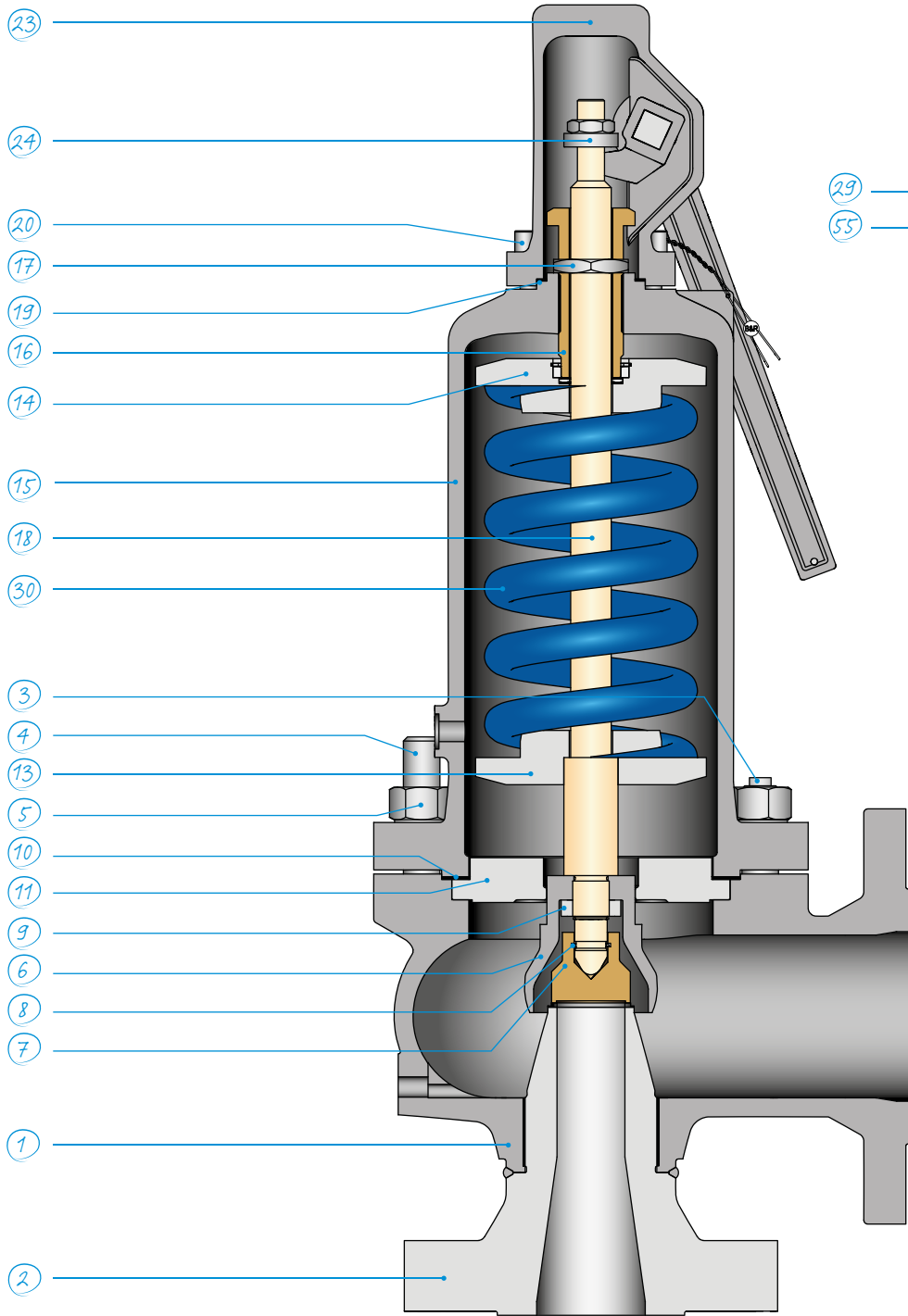

Bellows design Si 6404

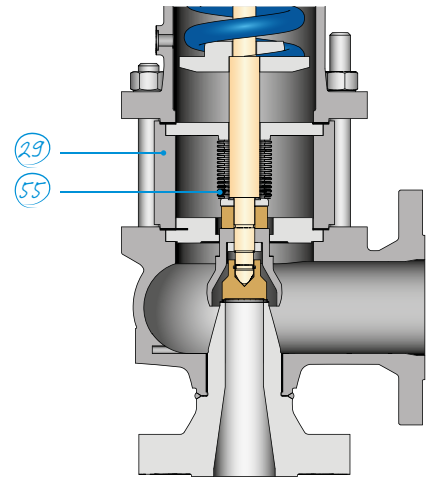

Si 6304

Material code			00	01	04
Temperature application range			-10 to +450 °C ¹⁾	Max. 550 °C	-200 to +400 °C ²⁾
Part	Name	Spare part	Material	Material	Material
1	Body		GP240GH/ 1.0619	G17CrMo5-5/ 1.7357	GX5CrNi-Mo19-11-2/ 1.4408
2	Inlet nozzle ⁷⁾		1.0460 1.0619 Seat surface hard-faced with Stellite	1.7335 1.7357 Seat surface hard-faced with Stellite	1.4571 1.4408 Seat surface hard-faced with Stellite
3	Stud, short		1.7709	1.7709	A4-70
4	Stud, long		1.7709	1.7709	A4-70
5	Hexagon nut		04	04	04
6	Disc holder		1.0460 5.3106/ GGG-40	1.4571 1.4408	1.4571 1.4408
7	Disc	*2, 3	1.4122 Hardened	1.4122 Hardened	1.4571 Seat surface hard-faced with Stellite
8	Disc retainer		1.4571	1.4571	1.4571
9	Groove nut		1.4571	1.4571	1.4571
10	Flat gasket	*1, 2, 3	1.4401 / graphite	1.4401 / graphite	1.4401 / graphite
11	Intermediate cover ⁹⁾		1.4122	1.4122	1.4571 1.4408
13	Spring washer, bottom		1.0460	1.4571	1.4571
14	Spring washer, top		1.0460	1.4571	1.4571
15	Bonnet ^{4) 6)}		GP240GH/ 1.0619	G17CrMo5-5/ 1.7357 ⁵⁾	GX5CrNi-Mo19-11-2/ 1.4408
16	Adjusting screw		1.4122	1.4571	1.4571
17	Lock nut		1.7258	1.7258	1.4571
18	Spindle		1.4122	1.4122	1.4571
19	Flat gasket	*1, 2, 3	1.4401 / graphite	1.4401 / graphite	1.4401 / graphite
20	Cylinder bolt		8.8	8.8	A4-70
23	Packed lifting lever (cap) ³⁾		1.0619	1.0619	1.4408
24	Lifting nut		1.4401	1.4401	1.4401
29	Bonnet spacer		1.0460	1.7335	1.4571
30	Spring ⁸⁾	*3	1.1200 1.8159	1.1200 1.8159	1.4310 1.8159, chem. nickel plated
55	Bellows	*3	1.4571	1.4571	1.4571

¹⁾ Material may be used in temperatures down to -85 °C if the specification of AD 2000-Merkblatt W10 is complied with.

²⁾ Material may be used in temperatures down to -273 °C if the specification of AD 2000-Merkblatt W10 is complied with.

³⁾ Packed lifting lever (cap) from DN 50 x 80 flanged Si 61 design with open bonnet only for valves acc. to material code "00" and "01".

⁵⁾ Bonnet in GP240GH/1.0619 for valves with open bonnet Si 61, Si 64 with bellows or with design option .15.

⁶⁾ Si 63 type valves with closed bonnet with design option .15 above 400 °C.

⁷⁾ Inlet nozzle up to seat ø 77 mm and with weld end always in forged steel, flow diameter ø 93 mm and above in cast steel.

⁸⁾ The spring material selection depends on the valve size and set pressure as well as the temperature. Other spring materials are available for special operating conditions, e.g. temperatures > 400 °C or < -170 °C, and if the customer specifies this.

⁹⁾ Intermediate cover for valves acc. to material code 00 and 01 up to DN 125 x 200 made from 1.4122, above this made from 1.4408.

Spare Parts:

*1 For start-up

*2 For 2 years of operation

*3 After several years of operation

All safety valves in pressure class 5 are equipped with a needle bearing between the adjusting screw and upper spring washer.

IMI Bopp & Reuther reserve the right to technical changes or application of higher quality materials without prior notice. The material design can be tailored to customer specifications at any time upon request.

Si 6304

Sizes, pressure ranges and dimensions

Size	DN _E	25	32	40	40	40	50	65	80	80	80	100	125	150	150	200	200	250	300
	DN _A	40	50	50	65	80	80	100	100	125	150	150	200	200	250	250	300	350	400
Flow diameter [mm] d ₀		16	20	20	25	25	32	40	40	50	50	63	77	77	93	110	125	155	180
Flow area [mm ²] A ₀		201	314	314	491	491	804	1257	1257	1964	1964	3117	4657	4657	6793	9503	12270	18870	25450
Min. set pressure [bar g]	Si 61/ Si 63	0.45	0.45	0.45	0.45	0.45	0.45	0.45	0.45	0.45	0.45	0.45	0.45	0.45	0.45	0.45	0.45	0.45	0.45
	Si 65/ Si 64	2.0	2.0	2.0	2.0	2.0	2.0	2.0	2.0	2.0	2.0	2.0	2.0	2.0	2.0	2.0	2.0	2.0	2.0
Max. set pressure ¹⁾ [bar g]		95	95	95	95	95	95	95	95	78	78	62	40	40	32	20	16	12	10
Max. back pressure ²⁾ [bar g]		24	24	24	24	24	24	24	24	20	20	15	10	10	8	5	4	3	3
Inlet flange DIN EN ⁴⁾		PN 63														PN 25/40		PN 25	
		PN 100																	
		PN 160		PN 160															
Outlet flange DIN EN ⁴⁾		PN 25/40												PN 25					
														PN 10/16					
Centre to face dimension S1 [mm]		100	110	110	130	130	145	155	155	190	190	210	215	215	225	240	265	300	335
Centre to face dimension S2 [mm]		120	125	125	140	140	150	165	175	185	185	200	220	260	245	270	290	340	370
Height H1 [mm]		430	485	485	535	535	650	680	680	795	795	940	960	960	1020	1125	1210	1210	1480
Height H2 [mm]		515	580	580	645	645	765	815	815	945	945	1060	1080	1080	1180	1295	1380	1580	1700
Additional height H3 f. actuator AK [mm]		222	205	205	205	205	267	267	267	267	267	394	394	394	394	310	310	490	490
Drain size E ³⁾		G ¹ / ₄	G ¹ / ₄	G ¹ / ₄	G ¹ / ₄	G ¹ / ₄	G ¹ / ₄	G ³ / ₈	G ³ / ₈	G ³ / ₈	G ³ / ₈	G ³ / ₈	G ¹ / ₂	G ¹ / ₂	G ¹ / ₂	G ³ / ₄	G ³ / ₄	G ³ / ₄	G ³ / ₄
Weight Si 61/63 [kg]		14	19	20	28	30	40	50	52	80	85	126	135	140	170	230	270	370	480
Weight Si 64/65 and Si 61/63.15 [kg]		17	22	24	32	34	44	55	57	88	93	140	165	170	200	270	320	425	550
Additional weight actuator AK [kg]		12	12	12	12	12	37	37	37	37	37	76	76	76	76	76	76	175	175

¹⁾ Stated pressures are maximum values corresponding to the spring forces. The component strength may need to be reviewed, and the suitable pressure rating selected, depending on the material and temperature.

²⁾ Or in accordance with the pressure rating at the outlet.
³⁾ Drain E is only drilled into the body if condensate formation is to be expected.

⁴⁾ Flanges acc. to DIN EN 1092-1; facings up to PN 40 type B 1, from PN 63 type B 2

Si 6304

Si 6304
Si 6104

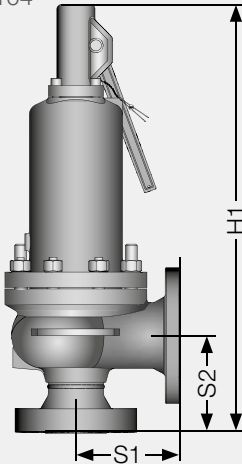

Si 6404
Si 6504

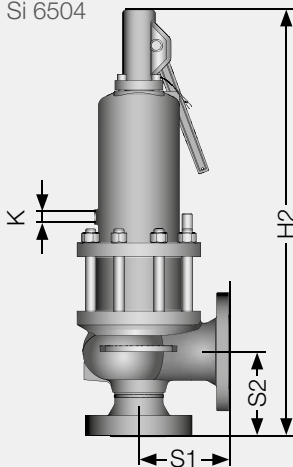

Actuator AK

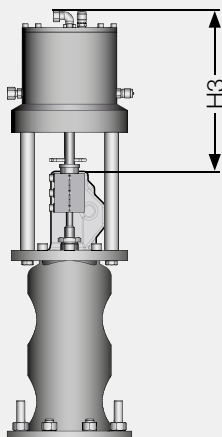

Support brackets

Size DN _E × DN _A	A	B	C	D	E	L	Support bracket thickness	Number of screws
40 x 65	186	93	140	70	156	14	12	4 x M 12
50 x 80	210	95	165	70	180	14	12	4 x M 12
65 x 100	250	95	205	70	220	14	12	4 x M 12
80 x 125	295	120	240	90	260	18	15	4 x M 16
100 x 150	320	120	265	90	285	18	15	4 x M 16
125 x 200	365	120	300	90	330	18	15	4 x M 16
150 x 250	415	150	360	120	380	18	15	4 x M 16
200 x 250	455	180	400	150	420	18	15	4 x M 16
200 x 300	510	180	450	150	470	23	20	4 x M 20
250 x 350	620	190	560	160	580	23	20	4 x M 20
300 x 400	695	210	600	180	655	23	20	4 x M 20

Dimensions in mm

The height from the inlet to the lower edge of the support bracket is identical with the centre to face dimension S2.

Support brackets will only be drilled if specified by the customer.

The bonnet for bellows seal design is provided with the test connection K. K up to DN 50 x 80 – G1/4", above G3/8".

Support brackets

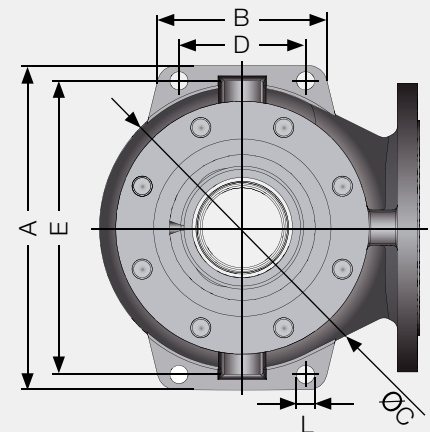

Si 6305

Material code

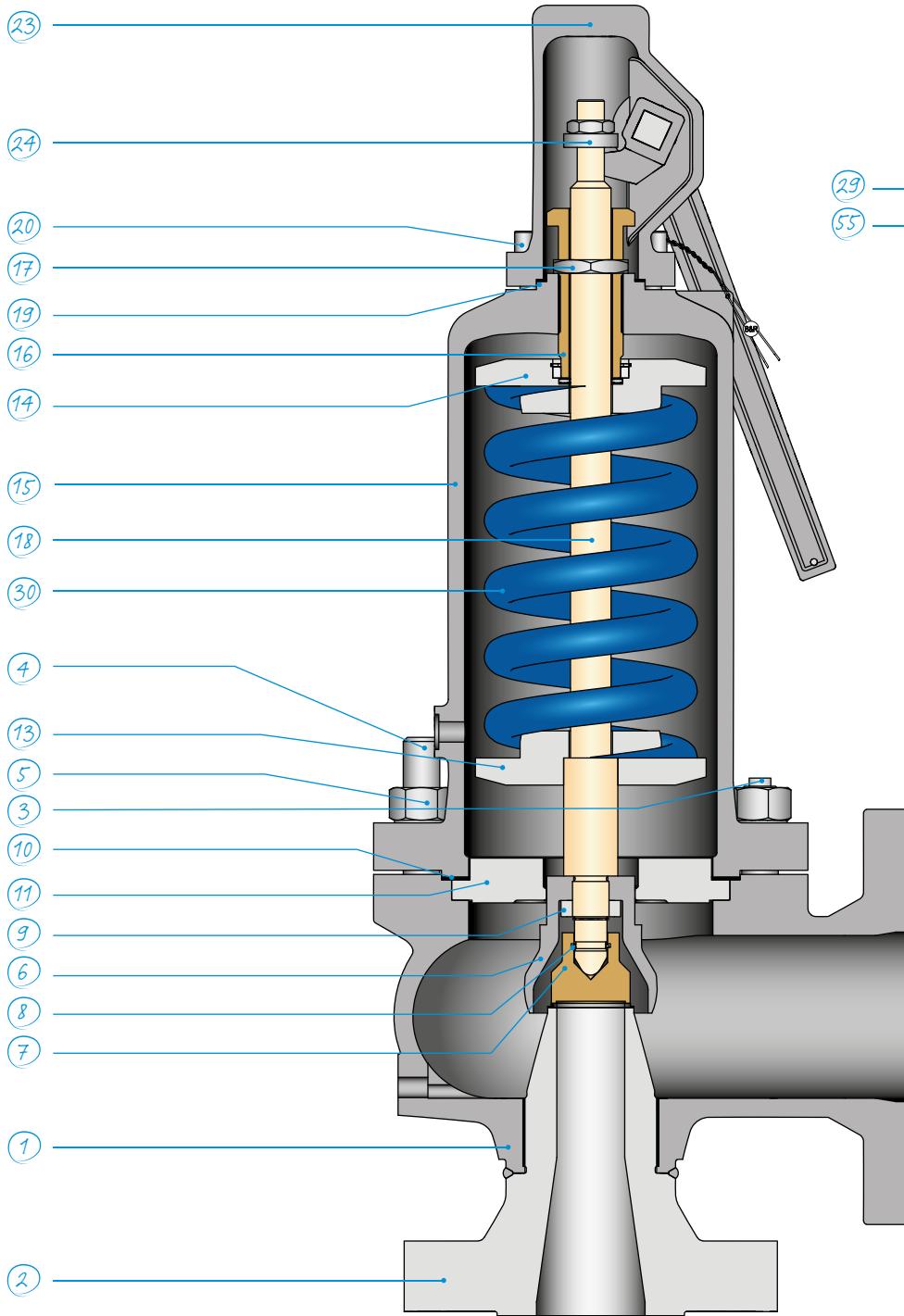

Bellows design Si 6405

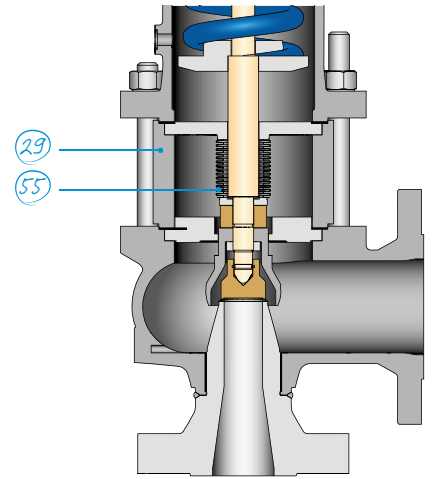

Si 6305

Material code		00	01
Temperature application range		-10 to + 450 °C ¹⁾	Max. 550 °C
Part	Name	Spare part	Material
1	Body		GP240GH/ 1.0619
2	Inlet nozzle ⁵⁾		1.0460 1.0619 Seat surface hard-faced with Stellite
3	Stud, short		1.7709
4	Stud, long		1.7709
5	Hexagon nut		04
6	Disc holder		1.0460 5.3106 / GGG-40
7	Disc	*2, 3	1.4122 Hardened
8	Disc retainer		1.4571
9	Groove nut		1.4571
10	Flat gasket	*1, 2, 3	1.4401 / graphite
11	Intermediate cover ⁷⁾		1.4122
13	Spring washer, bottom		1.0460
14	Spring washer, top		1.0460
15	Bonnet ⁴⁾		GP240GH/ 1.0619
16	Adjusting screw		1.4122
17	Locknut		1.7258
18	Spindle		1.4122
19	Flat gasket	*1, 2, 3	1.4401 / graphite
20	Cylinder bolt		8.8
23	Packed lifting lever (cap) ²⁾		1.0619
24	Lifting nut		1.4401
29	Intermediate spacer		1.0460
30	Spring ⁶⁾	*3	1.1200 1.8159
55	Bellows	*3	1.4571

¹⁾ Material may be used in temperatures down to -85 °C if the specification of AD 2000-Merkblatt W10 is complied with.

²⁾ Packed lifting lever (cap) from DN 50 x 80 flanged

³⁾ Bonnet in GP240GH/ 1.0619 for valves with open bonnet Si 61, with bellows Si 64 or with design option .15.

⁴⁾ Si 63 type valves with closed bonnet require design option .15 above 400 °C.

⁵⁾ Inlet nozzle up to seat ø 77 mm and with weld end option .22a is always manufactured in forging, flow diameter ø 93 mm and above in casting.

⁶⁾ The spring material selection depends on the valve size and set pressure as well as the temperature.

Other spring materials are available for special operating conditions, e.g. temperatures > 400 °C or < -170 °C, and if the customer specifies this.

⁷⁾ Intermediate cover for valves acc. to material code 00 and 01 up to DN 125 x 200 from 1.4122, above this from 1.4408.

Spare Parts:

*1 For start-up

*2 For 2 years of operation

*3 After several years of operation

All safety valves in pressure class 5 are equipped with a needle bearing between the adjusting screw and upper spring washer.

IMI Bopp & Reuther reserve the right to technical changes or application of higher quality materials without prior notice. The material design can be tailored to customer specifications at any time upon request.

Si 6305

Sizes, pressure ranges and dimensions

Size	DN _E	25	40	40	50	65	80	100	125	150	200	200	250	300	350	400
	DN _A	40	50	65	80	100	125	150	200	250	250	300	350	400	500	500
Flow diameter [mm] d ₀		16	20	25	32	40	50	63	77	93	110	125	155	180	220	255
				28	36	46	56	70	86	98	117	140	168	200	235	280
Flow area [mm ²] A ₀		201	314	491	804	1257	1964	3117	4657	6793	9503	12270	1887	25450	38010	51070
				615	1018	1662	2463	3848	5809	7543	10750	15390	22170	31420	43370	61575
Min. set pressure [bar g]	Si 61 / Si 63	0.45	0.45	0.45	0.45	0.45	0.45	0.45	0.45	0.45	0.45	0.45	0.45	0.45	0.45	0.45
	Si 64 / Si 65	2.0	2.0	2.0	2.0	2.0	2.0	2.0	2.0	2.0	2.0	2.0	2.0	2.0	2.0	2.0
Max. set pressure ¹⁾ [bar g]		250	250	230	220	180	145	115	77	53	43	33	23	18	12	10
				220	200	160	130	93	62	48	38	26	20	14	10	8
Max. back pressure ²⁾ [bar g]		40	40	40	40	40	40	24	16	12	10	8	6	4	3	2
								35								
Inlet flange DIN EN ⁴⁾		PN 63 - 160										PN 25/40		PN 25		PN 10 - 25
		PN 250								PN 63 / 100		PN 63	PN 40			
		PN 320														
		PN 400														
Outlet flange DIN EN ⁴⁾		PN 25 / 40								PN 10 - 25			PN 10 / 16	PN 10		
		PN 63														
		PN 100														
Centre to face dimension S1 [mm]	150	160	190	225	235	235	245	260	260	265	265	300	335	375	375	
Centre to face dimension S2 [mm]	150	160	170	190	220	220	220	260	290	300	340	355	370	415	415	
Height H1 [mm]	640	660	760	910	950	970	1040	1100	1150	1210	1260	1415	1480	1640	1640	
Height H2 [mm]	755	795	910	1060	1090	1110	1185	1230	1280	1380	1430	1595	1695	1825	1825	
Additional height H3 f. actuator AK [mm]	267	267	267	324	324	324	240	240	240	490	490	490	490	490	490	
Drain size E ³⁾	G ³ / ₄	G ³ / ₄	G ³ / ₄	G ³ / ₄	G ³ / ₈	G ³ / ₈	G ³ / ₈	G ³ / ₈	G ³ / ₈	G ¹ / ₂	G ¹ / ₂	G ³ / ₄	G ³ / ₄	G ³ / ₄	G ³ / ₄	G ³ / ₄
Weight Si 61/63 [kg]	42	57	83	110	120	175	205	230	245	280	320	400	500	630	680	
Weight Si 64/65 and Si 61/63.15 [kg]	46	62	88	115	127	185	222	263	281	330	385	478	590	735	785	
Additional weight actuator AK [kg]	37	37	37	80	80	80	80	80	80	175	175	175	175	175	175	

¹⁾ Stated pressures are maximum values corresponding to the spring forces. The component strength may need to be reviewed, and the suitable pressure rating selected, depending on the material and temperature.

²⁾ Or in accordance with the pressure rating of the outlet.
³⁾ Drain E is only drilled into the body if condensate formation is to be expected.

⁴⁾ Flanges acc. to DIN EN 1092-1; facings up to PN 40 type B 1, from PN 63 type B 2.

Si 6305

Si 6305
Si 6105

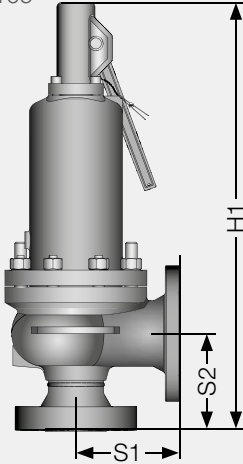

Si 6405
Si 6505

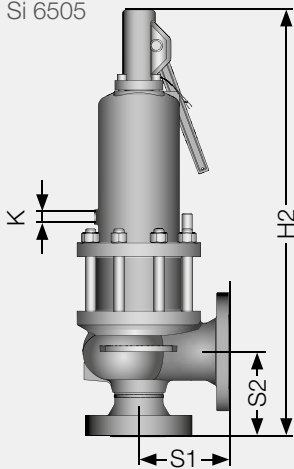

Actuator AK

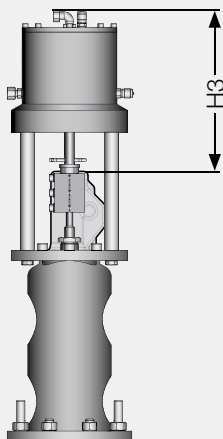

Support brackets

Size DN _E x DN _A	A	B	C	D	E	L	Support bracket thickness	Number of screws
40 x 65	250	70	175	45	220	14	13	4 x M 12
50 x 80	315	80	230	55	280	18	13	4 x M 16
65 x 100	346	165	285	140	310	18	15	4 x M 16
80 x 125	355	165	290	140	320	18	15	4 x M 16
100 x 150	365	165	300	140	330	18	15	4 x M 16
125 x 200	400	170	340	135	360	18	15	4 x M 16
150 x 250	472	180	410	150	434	18	15	4 x M 16
200 x 250	516	180	460	150	480	18	15	4 x M 16
200 x 300	510	180	450	145	465	22	20	4 x M 20
250 x 350	620	190	560	160	580	22	20	4 x M 20
300 x 400	695	210	600	180	655	22	20	4 x M 20
400 x 500	800	230	715	200	760	22	20	4 x M 20

Dimensions in mm

The height from the inlet to the lower edge of the support bracket is identical with the centre to face dimension S2.

Support brackets will only be drilled if specified by the customer.

The bonnet for bellows seal design is provided with the test connection K. K up to DN 50 x 80 – G¼", above G¾".

Support brackets

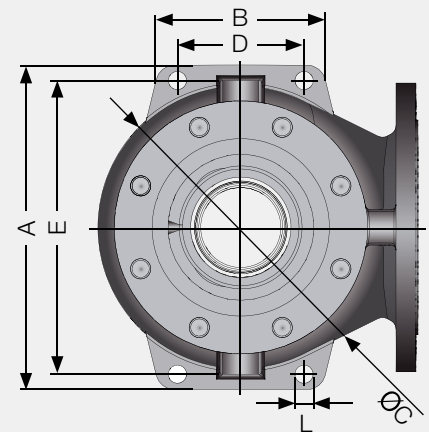

Si 6106

Features

The IMI Bopp & Reuther high pressure steam safety valve:

- > Solid inlet nozzle, screwed in and welded the inlet in accordance with customer specifications
- > Manages the high forces in the pressure adjustment via clamping plate and upper pressure ring
- > Material designs for high temperatures with the option to select the material at
- > Ideal for combination with the pneumatic actuator AK as well as the PC 50/53 control unit for "controlling" the discharge process

Inlet sizes

DN 80 to DN 300

Inlet pressure rating

PN 40 to PN 400

Set pressures

15 bar g to 200 bar g

Temperature range

Up to 550 °C

Overpressure

Vapours / gases 5%

Blow down

Vapours / gases 10%

Allowable built-up back pressure

25% of the set pressure

Engineered specific for HP steam application

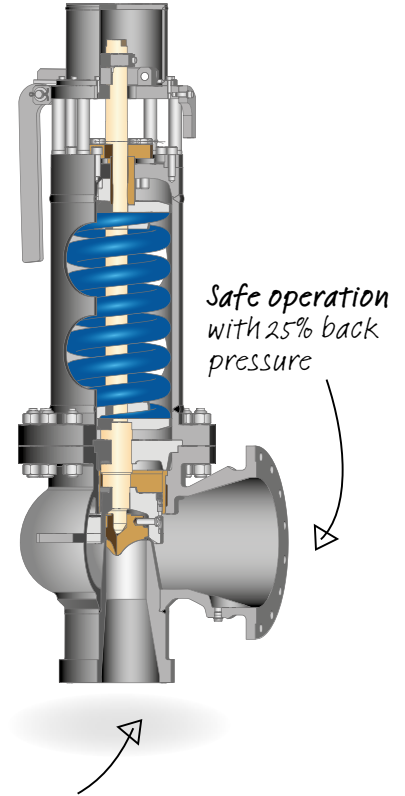

Full nozzle design

Applications

- > Steam boiler
- > Superheater
- > Power plants and industrial steam generators
- > Steam temperatures above 500 °C
- > Large flow diameter with high pressures

Approvals and standards

EC type examination

- Pressure Equipment Directive 97 / 23 / EC
- DIN EN ISO 4126-1
- AD 2000-Merkblatt A2
- VdTÜV Merkblatt "Sicherheitsventil 100"

VdTÜV type approval acc. to

TÜV.SV.10-138.d₀.D / G.α_w.p

IMI Bopp & Reuther will not renew the existing VdTÜV type approvals. The requirements by VdTÜV and applicable standards are completely considered by the EC type examination.

The design, manufacture, testing and labelling meet the requirements of DIN EN ISO 4126-7, DIN EN 12266-1 / -2 (insofar as applicable to safety valves), DIN EN 1092 parts I and II Flanges, AD 2000-Merkblatt A4, AD 2000-Merkblatt HP0, technical rules for steam boiler TRD 110, TRD 421

Si 6106

Type code

Type code				Order example
1	Series	Si 6	DIN/EN Full lift valve	Si 6
2	Design	1	Conventional, open bonnet	1
3	Characteristic	0	High capacity "High Flow"	0
4	Pressure class	6	Up to PN 400	6
5	Cap	AB	Lifting lever with test gag	AK
		AK	Pneumatic actuator	
6	Material code ²⁾	00	GP240GH / 1.0619	00
		01	G17CrMo5-5 / 1.7357	
		11	G17CrMo9-10 / 1.7379	
7	Options	.09	Locking sleeve (government ring)	.22a
		.14a	Lift indication with inductive proximity switch in the cap	
		.14b	Lift indication with inductive proximity switch in the auxiliary housing	
		.14c	Lift indication with inductive proximity switch for exposed spindle with actuator AK	
		.22a	Weld end at inlet	
		.22b	Weld end at outlet	
		.25	Block body design	
		.35	Lift restriction ring	
		.59	Stellited disc	
	.60	Stellited seat		

¹⁾ For valves with weld ends, please state the pipe's outer diameter, wall thickness and joint type code in your order. See page 39 for information on standard dimensions.

²⁾ The standard materials of the material codes can be changed by selecting trim codes. Please see page 44 for information on our trim codes T1, T2, T3.

Type ▶	Si 6106 AK 00 .22a
Please state ▶	Set pressure 105 bar g
	Fluid temp. 400 °C
	Fluid and State Superheated steam, Steam
	Inlet DN 100, weldend
	Weld end dimensions ¹⁾ 117 x 14.2 mm
	Outlet DN 150, PN 100, B2
	Flow diameter 63 mm
	Approval 97 / 23 / EG (CE)

Si 6106

Sizes, pressure ranges and dimensions

Fluid group	Inlet size	Flow diameter	$h/d_0 \geq$	$p_b/p_0 \leq$	α_w
Vapours / gases (D / G)	DN 80 to DN 200	56 mm up to 140 mm	0.36	0.25	0.81
	DN 250 to DN 300	155 mm up to 200 mm	0.38	0.3	0.78

The coefficient of discharge for gases/vapours in a pressure ratio of $p_b/p_0 > 0.25$ and/or $p_b/p_0 > 0.3$ is shown in the diagram below.

The capacity of the selected safety valves can be adjusted to the required capacity by reducing the lift, thus reducing undesirable extra performance. The following applies:

$\alpha_{w(\text{reduced})} = \alpha_w \times q_m/q_{mc}$. The required ratio h/d_0 is shown in the diagram below, and the reduced lift calculated with $h_{(\text{reduced})} = d_0 \times (h/d_0)$.

- h = Lift [mm]
- d_0 = Flow diameter of the selected safety valve [mm]
- h/d_0 = Lift/Flow diameter ratio
- p_b = Absolute back pressure [bar a]
- p_0 = Absolute relieving pressure [bar a]

- p_b/p_0 = Absolute back pressure / absolute relieving pressure ratio
- α_w = Coefficient of discharge acc. to AD 2000-Merkblatt A2
- q_m = Required mass flow [kg/hr]
- q_{mc} = Certified mass flow [kg/hr]

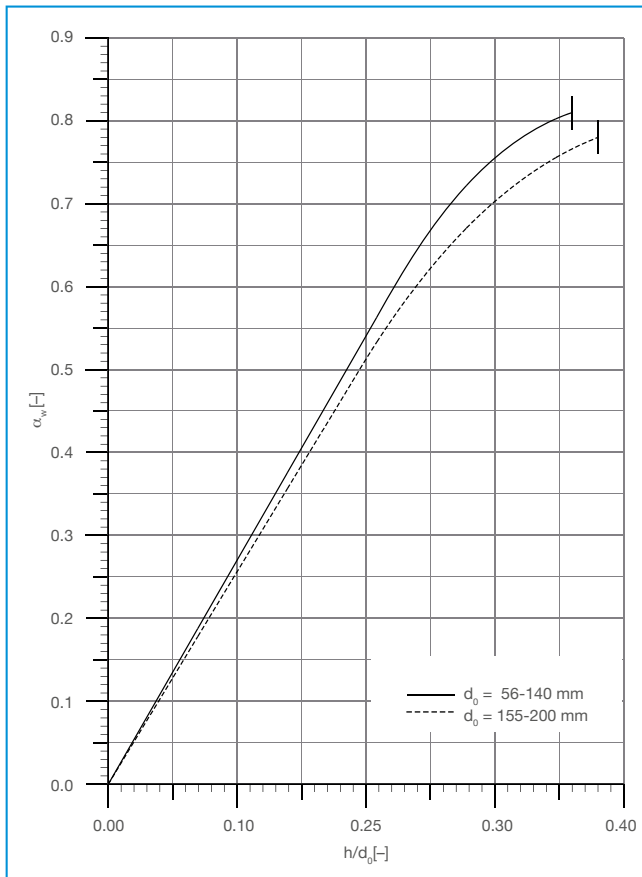

Si 6106 coefficient of discharge α_w depending on h/d_0 for gases and vapours

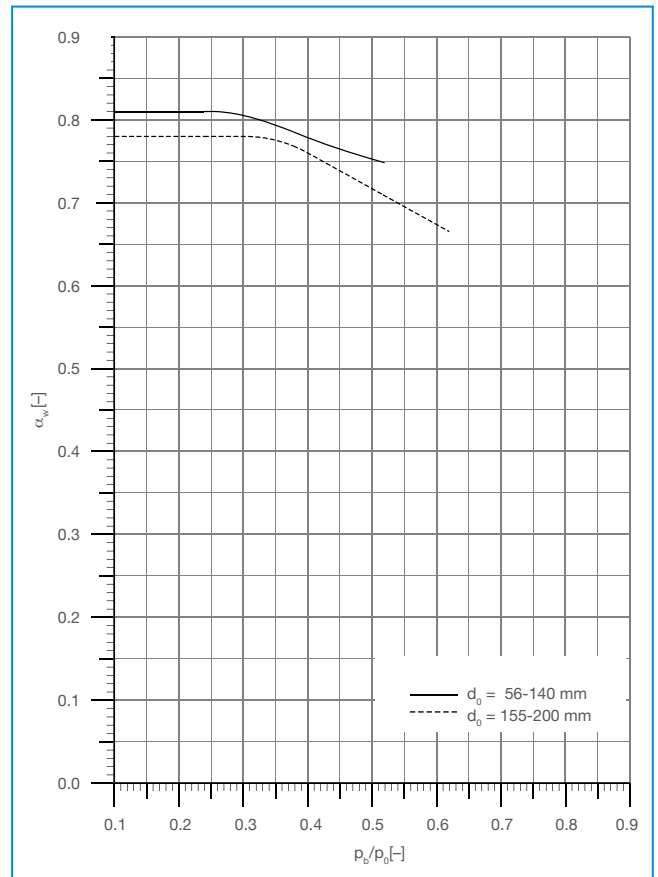

Si 6106 coefficient of discharge α_w depending on p_b/p_0 for gases and vapours

Weld end

Weld end (option .22) for Si 6106, as well as the series Si 6303, Si 6304 and Si 6305

Weld ends are mainly used for applications with high pressure and high temperatures. The following table shows the standard IMI Bopp & Reuther dimensions acc. to DIN EN 12627. This European standard defines the dimensions for weld ends of steel valves that are welded to standardized pipes. The outside diameters and wall thicknesses of the standardized pipes are described in DIN EN 1092-1.

The shape and dimensions of weld ends can be changed upon request.

The centre to face dimensions S2 for safety valves with weld end are as a standard identical with the centre to face dimensions of the same type with flange at the inlet. The centre to face dimensions can also be tailored to customer specifications.

Example:

Weld end P 250 GH (1.0460);
114.3 x 3.6 (acc. to DN 100 PN 40)

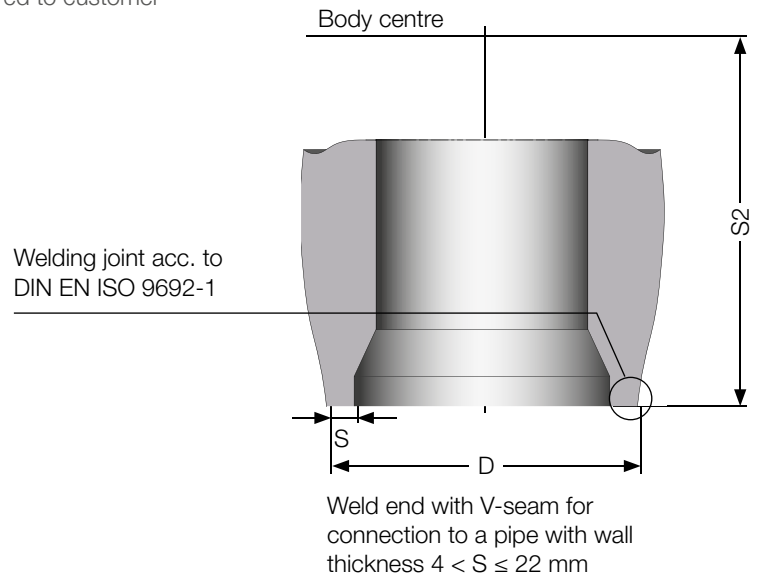

Specification of the weld end (must be stated in your order)

1. Inlet nozzle material
2. Weld end dimensions
 - 2.1 Outer diameter D
 - 2.2 Wall thickness S

Standard dimensions

DN	ØD [mm] DIN EN 12627	PipeØ [mm] DIN EN 1092-1	Wall thickness S [mm]							
			PN 16	PN 25	PN 40	PN 63	PN 100	PN 160	PN 250	PN 320
15	22	21.3	2.0	2.0	2.0	2.0	3.2	3.2	3.2	3.2
20	28	26.9	2.3	2.3	2.3	2.6	3.2	n. v.	n. v.	n. v.
25	35	33.7	2.6	2.6	2.6	2.6	3.6	3.6	3.6	5.0
32	44	42.4	2.6	2.6	2.6	2.9	3.6	n. v.	n. v.	n. v.
40	50	48.3	2.6	2.6	2.6	2.9	3.6	3.6	5.0	6.3
50	62	60.3	2.9	2.9	2.9	4.0	4.0	4.0	6.3	8.0
65	77	76.1	2.9	2.9	2.9	4.0	4.0	5.0	8.0	11.0
80	91	88.9	3.2	3.2	3.2	4.5	5.0	6.3	11.0	12.5
100	117	114.3	3.6	3.6	3.6	4.5	5.6	8.0	14.2	16.0
125	144	139.7	4.0	4.0	4.0	5.6	6.3	10.0	16.0	20.0
150	172	168.3	4.5	4.5	4.5	6.3	8.0	12.5	17.5	25.0
200	223	219.1	6.3	6.3	6.3	7.1	8.8	16.0	25.0	30.0
250	278	273.0	6.3	7.1	7.1	8.8	10.0	20.0	32.0	40.0
300	329	323.9	7.1	8.0	8.0	11.0	12.5	22.2	n. v.	n. v.
350	362	355.6	8.0	8.0	8.8	12.5	14.2	n. v.	n. v.	n. v.
400	413	406.4	8.0	8.8	11.0	14.2	16.0	n. v.	n. v.	n. v.

n. a. not available

Si 6106

Material code

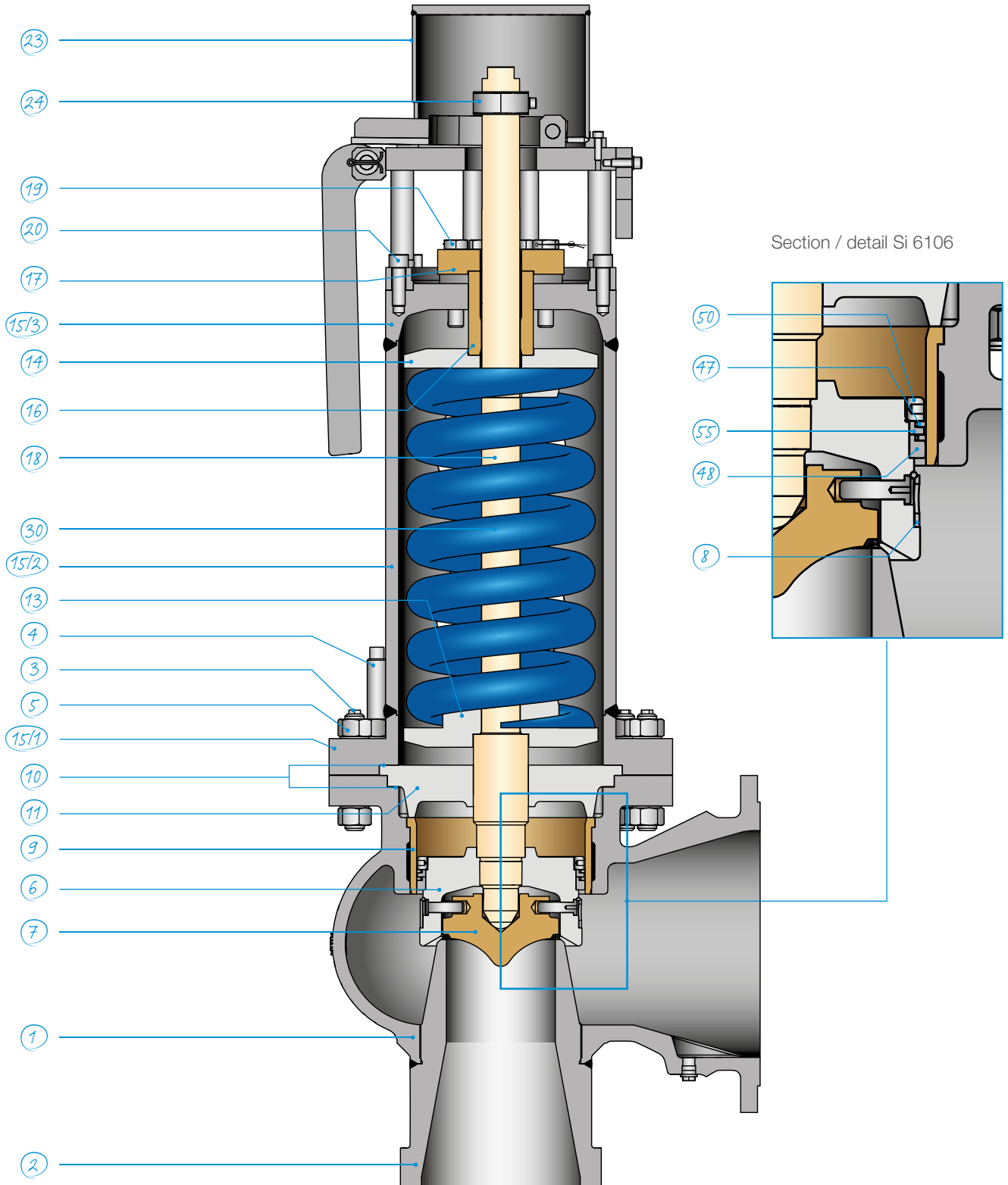

Si 6106

Material code			00	01	11
Temperature application range			-10 to +450 °C	Max. 530 °C	Max. 600 °C
Part	Name	Spare part	Material	Material	Material
1	Body		GP240GH / 1.0619	G17CrMo5-5 / 1.7357	G17CrMo9-10 / 1.7379
2	Inlet nozzle		P250GH / 1.0460 Seat surface hard-faced with Stellite	13CrMo4-5 / 1.7335 Seat surface hard-faced with Stellite	10CrMo9-10 / 1.7380 Seat surface hard-faced with Stellite
3	Stud, short		1.7709	1.7709	1.7709
4	Stud, long		1.7709	1.7709	1.7709
5	Hexagon nut		1.7258	1.7258	1.7258
6	Lift collar		1.0460	1.4122	1.4122
7	Disc ¹⁾	*2	1.4122 Hardened	1.4122 Hardened	1.4122 Hardened
8	Locking ring		1.7380	1.7380	1.7380
9	Guiding bush	*3	1.4122 Hardened	1.4122 Hardened	1.4122 Hardened
10	Flat gasket		1.4401 / graphite	1.4401 / graphite	1.4401 / graphite
11	Intermediate cover		1.4122	1.4122	1.4122
13	Spring washer, bottom		1.4122	1.4122	1.4122
14	Spring washer, top		1.4122	1.4122	1.4122
15 / 1	Lower bonnet flange		1.0425	1.0425	1.0425
15 / 2	Bonnet cylinder		1.0305	1.0305	1.0305
15 / 3	Upper bonnet flange		1.0425	1.0425	1.0425
16	Holding bushing		1.4122	1.4122	1.4122
17	Clamping plate		1.4122	1.4122	1.4122
18	Spindle		1.4122	1.4122	1.4122
19	Hexagon nut		8.8	8.8	8.8
20	Cylinder bolt		1.0109	1.0109	1.0109
23	Lifting lever (cap)		1.0460	1.0460	1.0460
24	Lifting nut		1.4122	1.4122	1.4122
30	Spring		1.8159	1.8159	1.8159
47	Piston ring	*2	1.4086	1.4086	1.4086
48	Guide ring	*3	1.4086	1.4086	1.4086
50	Cap nut		1.4122	1.4122	1.4122
55	Piston ring guide		1.4122	1.4122	1.4122

¹⁾ 1.4122 hardened, running surfaces hard chrome plated

Spare Parts:
*1 For start-up
*2 For 2 years of operation
*3 After several years of operation

IMI Bopp & Reuther reserve the right to technical changes or application of higher quality materials without prior notice. The material design can be tailored to customer specifications at any time upon request.

Si 6106

Sizes, pressure ranges and dimensions

Size	DN _E	80	100	100	125	125	150	150	200	200	200	200	250	250	300	300
	DN _A	150	150/200	150/200	250	250	250	250	250	250	300	300	350	350	400	400
Flow diameter [mm] d ₀		56	63	70	77	86	93	98	110	117	125	140	155	168	180	200
Flow area [mm ²] A ₀		2463	3117	3848	4657	5809	6793	7543	9503	10751	12272	15394	18869	22167	25447	31416
Min. set pressure [bar g]		70	60	60	50	50	40	40	30	30	25	25	15	15	15	15
Max. set pressure ¹⁾ [bar g]		200	180	180	150	150	125	125	100	100	75	75	50	50	45	45
							(95) ²⁾	(85) ²⁾	(65) ²⁾	(60) ²⁾	(54) ²⁾	(44) ²⁾	(35) ²⁾	(31) ²⁾	(26) ²⁾	(20) ²⁾
Max. back pressure [bar g]		30	27	27	22.5	22.5	18.7	18.7	15	15	11.2	11.2	7.5	7.5	6.7	6.7
Inlet flange DIN EN ³⁾		PN 100										PN 100		PN 40/63		
		PN 160														
		PN 250														
		PN 400														
Outlet flange DIN EN ³⁾												PN 16		PN 16/10		
		PN 40					PN 25 / 40					PN 25				
		PN 63 / 100			PN 63											
Centre to face dimension S1 [mm]		290	290	330	300	300	295	295	340	340	305	305	400	400	455	455
Centre to face dimension S2 [mm]		260	270	280	330	330	400	400	335	335	360	360	375	375	440	440
Height H1 [mm]		1400	1400	1400	1400	1400	1400	1400	1600	1600	1600	1600	1850	1850	2000	2000
Additional height H3 f. actuator AK [mm]		490	490	490	490	490	490	490	490	490	490	490	490	490	490	490
Drain size E ⁴⁾		G½	G½	G½	G½	G½	G½	G½	G½	G½	G½	G½	G½	G½	G½	G½
Weight Si 61 [kg]		220	250	250	285	285	305	305	305	355	400	400	510	510	890	910
Additional weight actuator AK [kg]		175	175	175	175	175	175	175	175	175	175	175	175	175	175	175

¹⁾ Stated pressures are maximum values corresponding to the spring forces. The component strength may need to be reviewed depending on the material and temperature.

²⁾ Maximum set pressure if the pneumatic actuator AK is used. Up to this pressure, the actuator force is sufficient for obtaining the desired function improvement.

³⁾ Flanges: acc. to DIN EN 1092-1; gasket facing up to PN 40 type B1, PN 63 and above type B2.

⁴⁾ Drain E is only drilled into the body if condensate formation is to be expected.

Si 6106

Si 6106

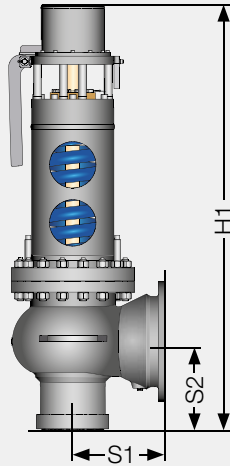

Actuator AK

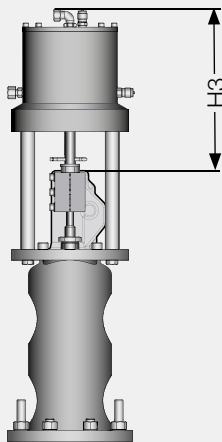

Support brackets

Size DN _E × DN _A	A	B	C	D	E	L	Support bracket thickness	Number of screws
80 x 150	350	120	265	75	305	22	20	4 x M 20
100 x 150	460	160	350	130	420	22	25	4 x M 20
100 x 200	450	140	340	90	390	27	25	4 x M 24
125 x 250	560	170	405	100	480	30	30	4 x M 27
150 x 250	550	210	420	150	480	33	35	4 x M 30
200 x 250	580	210	420	150	500	33	25	4 x M 30
200 x 300	600	210	420	150	530	33	25	4 x M 30
250 x 350	690	210	520	150	600	33	25	4 x M 30
300 x 400	820	270	660	200	730	39	35	4 x M 36

Dimensions in mm

The height from the inlet to the lower edge of the support bracket is identical with the centre to face dimension S2.

Support brackets will only be drilled if specified by the customer.

Support brackets

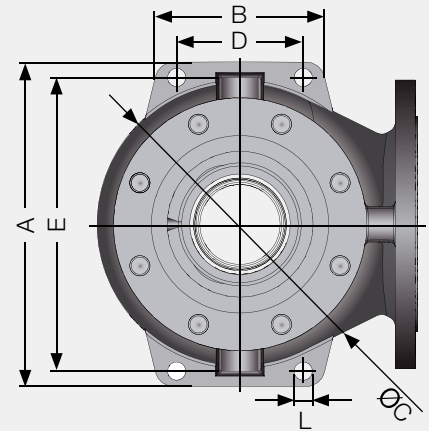

Trim code

Trim codes stand for the replacement of standard materials of named “trim parts” and allow the selected safety valve being suitable for special operating conditions. The trim codes T1 to T3 can increase the temperature application range of the

selected safety valve and therewith enable its use in high operating and discharge temperatures. With the series Si 6303 to Si 6106, the pressure of the system to be protected is applied to the one-piece solid inlet nozzle. Selecting a more temperature-

resistant material for the inlet nozzle can for example permit the selection of a lower inlet pressure rating or more economic material class.

Series	Material Code	Body material	Trim code	Material Inlet nozzle	Maximum application temperature	
Si 6xx3-5	00	1.0619 GP240GH	Standard	1.0460 ^{1) 3)}	P250GH	Up to 450 °C
Si 6106			T3	1.5415 ³⁾	16Mo3	Up to 450 °C
Si 6xx3-5	01	1.7357 G17CrMo5-5	Standard	1.7335 ^{1) 3)}	13CrMo4-5	Up to 530 °C ²⁾
Si 6106			T2	1.7380 ³⁾	10CrMo9-10	Up to 530 °C ²⁾
Si 6106	11	1.7379 G17Cr-Mo9-10	Standard	1.7380 ³⁾	10CrMo9-10	Up to 600 °C
Si 6106			T1	1.4903 ³⁾	X10CrMoVNb9-1	Up to 600 °C

¹⁾ Or made from equivalent cast material, see material list of the series

²⁾ Materials of Si 6xx3-5 usable in up to 550 °C

³⁾ Seat surface hard-faced with Stellite

The diagram below shows the maximum pressure/temperature graphs of the materials available for the inlet nozzle. The design-related maximum set pressure of every series and size acc. to table “Sizes, pressure ranges and dimensions” must be taken into account over and beyond this.

Example:

Si 6105 A 00, DN 65 x 100, PN 250 x 40, flow diameter 46 mm, can be used up to a maximum set pressure of 142 bar g at a discharge temperature of 400 °C.

With selection of trim code T3, the Si 6105 A 00-T3 safety valve can be used up to a maximum set pressure of 160 bar g, max. set pressure acc. to material characteristic 186 bar g, but series / size limited to 160 bar g; see table on page 34.

Trim code	T3	T2	T1
Body	1.0619 / GP240GH	1.7357 / G17CrMo5-5	1.7379 / G17CrMo9-10
Inlet nozzle standard:	1.0460 / P250GH	1.7335 / 13CrMo4-5	1.7380 / 10CrMo9-10
Inlet nozzle trim code:	1.5415 / 16Mo3	1.7380 / 10CrMo9-10	1.4903 / X10CrMoVNb9-1

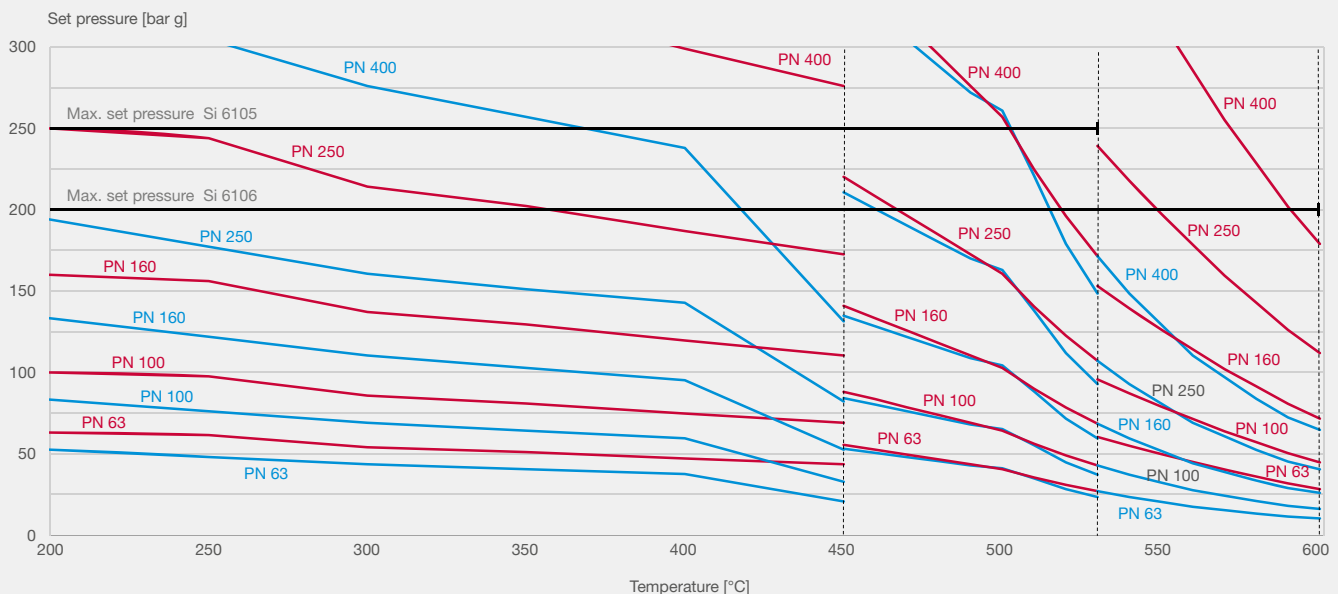

Controlled safety valve

Controlled safety pressure relief system

Spring-loaded safety valves are often unable to meet operating conditions such as a high operating pressure (> 90% of set pressure), stringent tightness requirements up to the set pressure, or reduced opening and reseal pressure difference.

With the pneumatic actuator AK and control units PC 50 or PC 53, the spring safety valve is turned into a controlled safety valve (CSPRS acc. to EN ISO 4126-5).

The control unit requires an external air supply. The triple redundant pressure switches of the control unit are connected with the pressure system to be protected and control the compressed air supply at the AK piston in accordance with their set pressure.

The loading air in the actuator AK increases the closing force up to the set pressure; activation of the optional lift air supports and stabilizes the discharge process.

The rules for sizing calculation of the required flow diameter correspond to the rules for spring-loaded valves. The series Si 4302 and Si 6303 to Si 6106 can be combined with an actuator AK.

Please see the IMI Bopp & Reuther catalogue "Pneumatic Control Unit PC 50" for more detailed information.

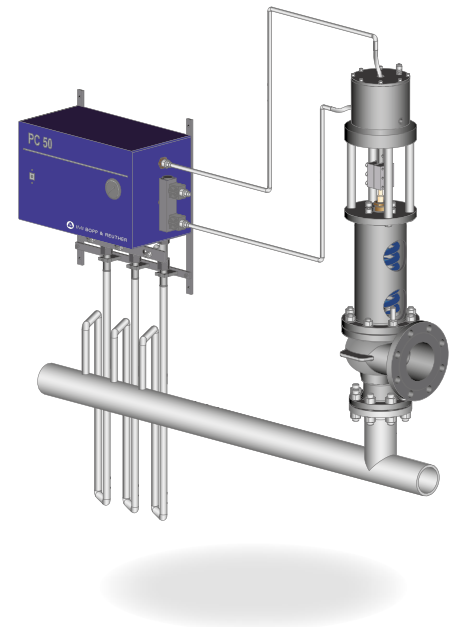

Pneumatic actuator AK

The pneumatic actuator AK follows the relief principle and uses differential surface pistons of a "flying piston" design. This ensures frictionless opening as a spring safety valve if the air supply fails.

The safety valve will no longer be gastight at the upper end of the bonnet once the actuator is set up. If a gastight design is required (typically for all applications except steam), a bellows design will need to be selected.

Part	Name	Material
60	Bonnet plate	P250GH / 1.0460
61	Coupling	1.0038
62	Column	GX35CrMo / 1.4122
63	Locking nut	1.0109
64	Spindle	GX35CrMo / 1.4122
65	Piston bushing	P250GH / 1.0460 (hard chrome-plated)
66	Lifting piston	GX35CrMo / 1.4122 size 1+2 GP240GH / 1.0619 size 3-5 (coated with zinc dust paint)
67	Loading piston	GX35CrMo / 1.4122 size 1+2 GP240GH / 1.0619 size 3-5 (coated with zinc dust paint)
68	Cover	P250GH / 1.0460
70	Spring	1.8159

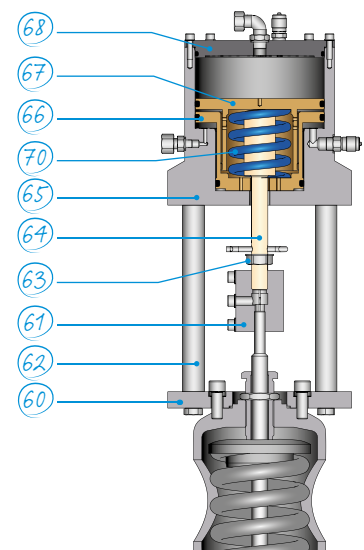

Heating jacket

Safety valve with heating jacket (Option .18)

Hardening or solidification of highly viscous media in the safety valve can interfere with the function or closing and hence lead to dangerous operating conditions. Media with a tendency to conglutination or crystallization can block the seat and moving parts. This can usually be remedied by maintaining the temperature of the Fluid before and during the discharge. Monitoring and heating the

pipe will often not provide the required heat to the inlet of the safety valve. Equipping the safety valve with a heating jacket will solve this problem. Typical applications for safety valves with heating jacket (option code .18) include ammonium nitrate, acrylic acid, sulphuric acid, fluoropolymers, polypropylene, olefins, and tar.

The safety valve should be equipped with bellows to protect the spindle and guides.

Additional heating of the isolating spacer is integrated in the heating circuit by means of piping. The bellows will not be required if the fluid does not tend to solidify in the outlet of the safety valve.

Purging the seat area with steam can serve as a further measure for protecting the safety valve seat from conglutination. The purge connection (option .32) can also be combined with the heating jacket.

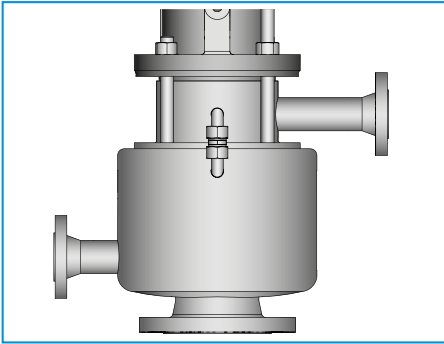

.18 Heating jacket with flange connection for safety valve with bellows

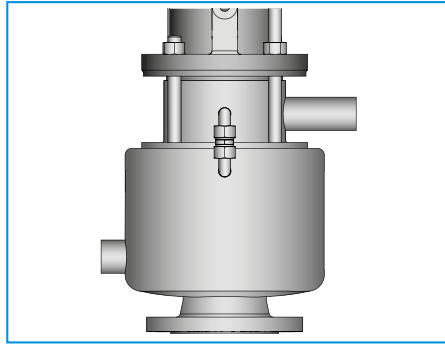

.18 Heating jacket with threaded connection for safety valve with bellows

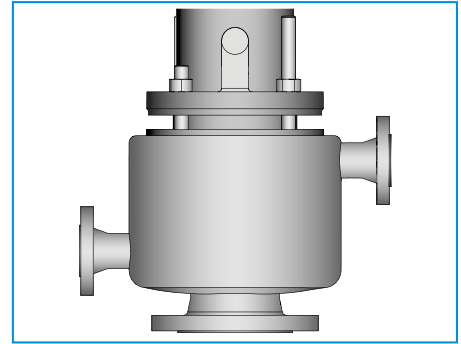

.18 Heating jacket with flange connection for conventional safety valve

Safety valve Inlet size	DN _E	25	32	40	50	65	80	100	150	200	≥ 250	
Heating jacket connection	Flange	DN 15 PN 25					DN 25 PN 25					
	Thread	G ³ / ₈					G ³ / ₄					
Max. heating jacket working pressure [bar g] ¹⁾	50 °C	25					16					10
	150 °C	22					14					9
	200 °C	21					13					8
	300 °C	18					12					7
Heating jacket material		Stainless steel 1.4301 ²⁾										

¹⁾ Nominal pressure rating for the heating jacket at 50 °C. The heating jacket is labelled in compliance with the Pressure Equipment Directive.

²⁾ Depending on the heating jacket design or availability of materials, we reserve the right to use higher quality 1.4404 or 1.4571 stainless steel.

Other connections, pressure ratings or materials available upon request. Safety valves with heating jacket have no support brackets.

Options

Technical design options

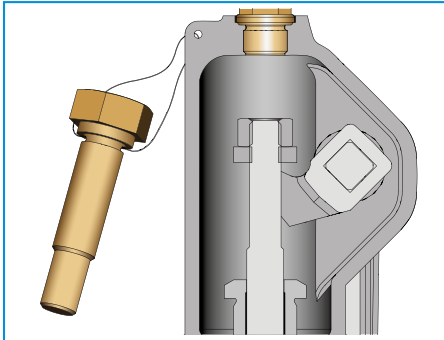

B Test gag: Blocking of the safety valve for pressure testing the pressure system.

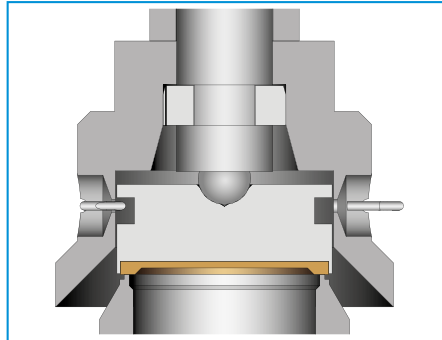

.11 Disc with soft seal for particularly high tightness.

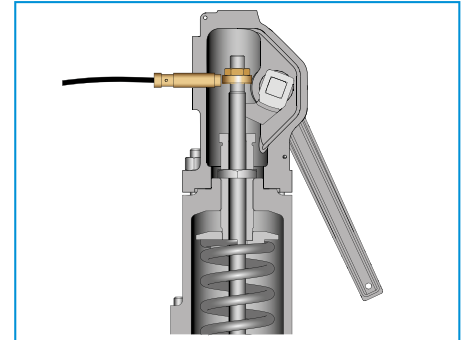

.14a Lift indication with inductive proximity switch in the cap. If the safety valve disc lifts by 1 mm minimum, the proximity switch will change its status and switch.

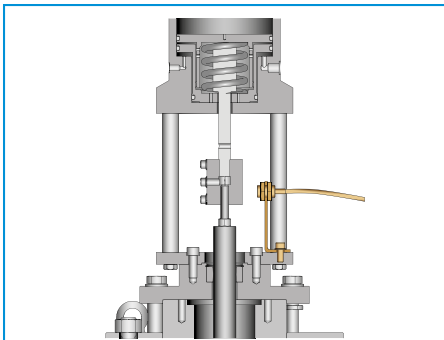

.14c Lift indication with inductive proximity switch for exposed spindle with actuator AK. If the safety valve disc lifts by 1 mm minimum, the proximity switch will change its status and switch.

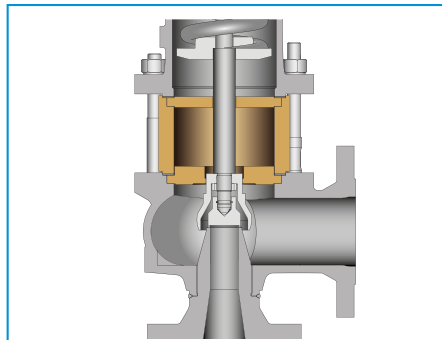

.15 Bonnet insulation spacer for protecting the spring against high and low temperatures.

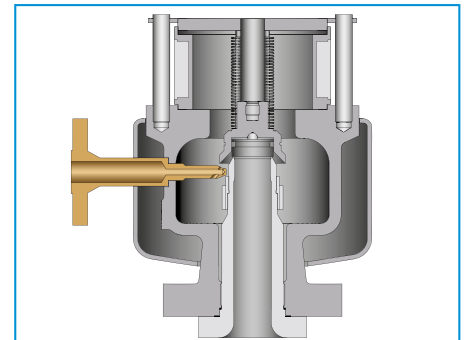

.32 Purge connection for constant cleaning of the safety valve seat and hence protecting it from conglutination.

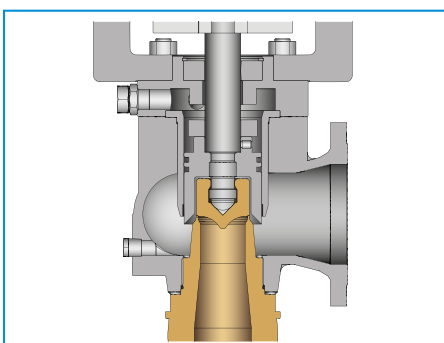

.22a Weld end at inlet.

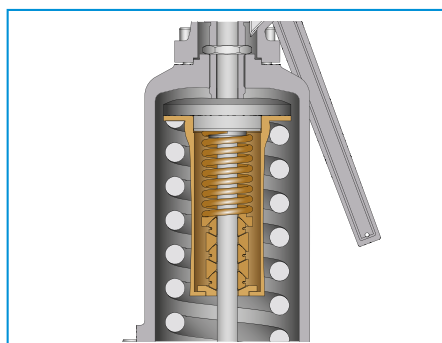

.38 Vibration damper for avoiding valve oscillation in case of unfavourable installation conditions.

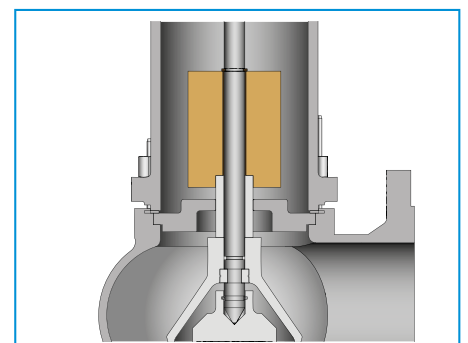

.57 Weight load for operation with very low set pressure.

IMI Bopp & Reuther

Bopp & Reuther Sicherheits-
und Regelarmaturen GmbH
Carl-Reuther-Straße 1
68305 Mannheim
Deutschland

Tel: +49 (0)621 76220-100
Fax: +49 (0)621 76220-120

www.imi-critical.com
imibur.sales@imi-critical.com

IMI Critical Engineering

Lakeside, Solihull Parkway
Birmingham Business Park
Birmingham B37 7XZ
United Kingdom

Tel: +44 (0)121 717 3700
Fax: +44 (0)121 717 3701

www.imi-critical.com